

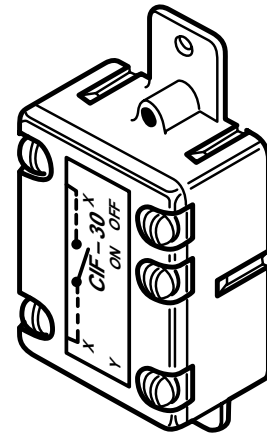

# Contact Interface Module (CIF)

Control of interconnected TR Relays

- 1 to 30 TR Relays may be controlled by maintained contact control devices or a saturated transistor
- Up to 10 CIFs may be connected in parallel and be controlled from a single point
- Can control up to 30 TRs if TRs are distributed evenly across three phases
- Can be interfaced with ILC's Interface Module (IFM) for zone control
- Can be mounted in an electrical outlet box with blank cover



## Overview

The ILC Contact Interface Module is a circuit to act as interface between an ILC Transformer Relay (TR-120, TR-120A, TR-277, TR-277A) or an ILC Interface Module (IFM) and a control. This control can take the form of a set of dry contacts or of a saturated transistor.

## Features

### Application

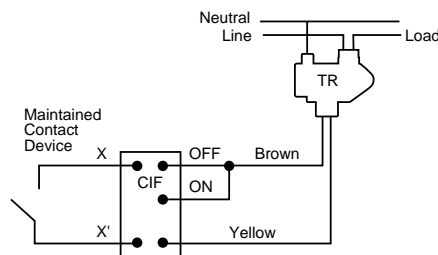

The CIF can be connected to one TR, or to several TRs through an IFM.

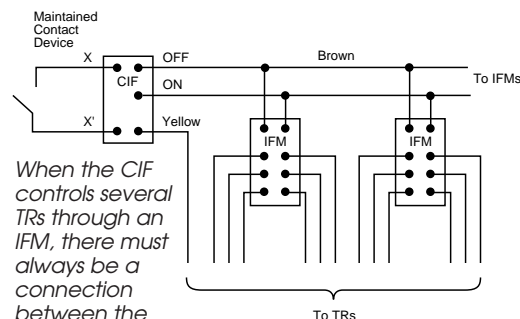

When the CIF controls several TRs through an IFM, there must always be a connection between the OFF terminals of the CIF and the IFM.

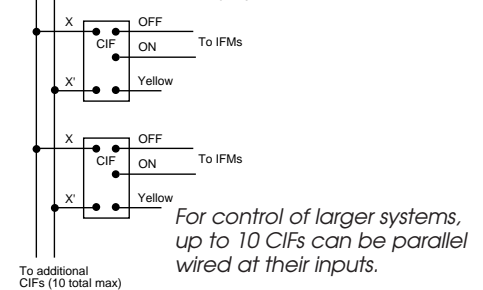
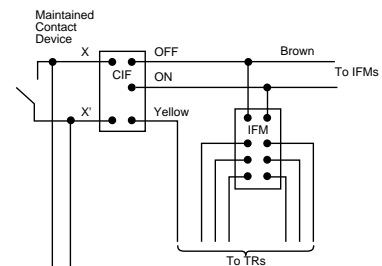

For control of larger systems, up to 10 CIFs can be parallel wired at their inputs.

INTELLIGENT LIGHTING CONTROLS, INC.

5229 Edina Industrial Boulevard  
Minneapolis, Minnesota 55439  
Phone 952 829 1900  
FAX 952 829 1901  
1-800-922-8004  
www.ilc-usa.com



# Contact Interface Module (CIF)

Control of interconnected TR Relays

## Physical Dimensions

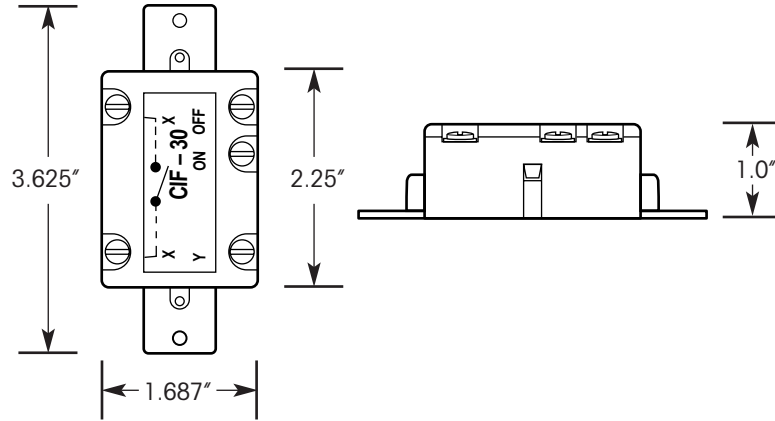

## Specifications

### Physical:

- Mounts in standard 4" outlet box
- Operates in any position

### Operating Environment:

- Location Interior Space
- Operating Temperature 0° to 50° C (32° to 112° F)
- Relative Humidity 10% to 95%  
Non-condensing
- Atmosphere Non-explosive,  
Non-corrosive
- Vibration Stationary application  
NEMA Level A

### Certifications:

- UL

INTELLIGENT LIGHTING  
CONTROLS, INC.

5229 Edina Industrial Boulevard  
Minneapolis, Minnesota 55439  
Phone 952 829 1900  
FAX 952 829 1901  
1-800-922-8004  
www.ilc-usa.com

### How to Order

Ordering an ILC **Contact interface  
Module**

Order No. CIF

**CIF**