

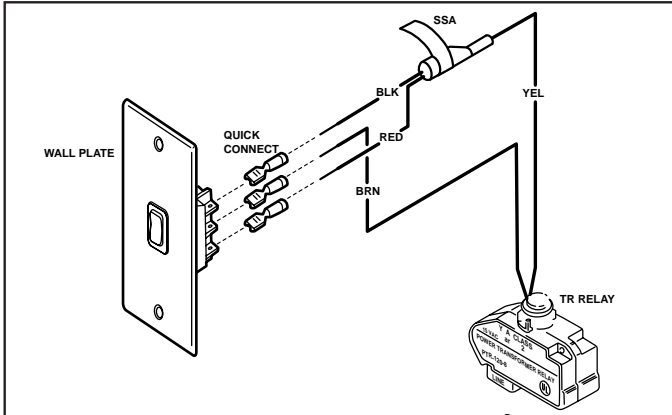

Component Operational Summary

Magnetically Latched Transformer Relay

NFP Positive Control Switches



The ILC NFP Positive Control Switch (NFP PCS) is a standard NFP SPDT momentary switch with a Standard Switch Adapter (SSA) for controlling a single Transformer Relay (TR). Any momentary SPDT with the use of a SSA can control a TR by directing the current flow in the appropriate direction. When toggled to "ON", the appropriate current flow direction is allowed and the TR responds accordingly. If the TR is "OFF", it will change states. If the TR is already "ON", it will remain in that state. Because the Transformer Relay responds to a momentary current flow, any number of NFP PCS can be wired in parallel and provide independent control.

Standard Switch Adapter (SSA)

Introduction: The SSA will convert any SPDT momentary contact switch with a minimum 200mA, 15 volt rating so that it can control a TR.

Operation: The SSA contains diodes arranged to polarize the current pulses in the correct direction to control the TR.

Application: The SSA can be used with any momentary switch. For example, if the decor of the building requires that switches be a color other than white or ivory. When replacing a pre-existing low voltage control system with ILC Transformer Relays, the designer could elect to add a SSA to each existing SPDT momentary contact switch.

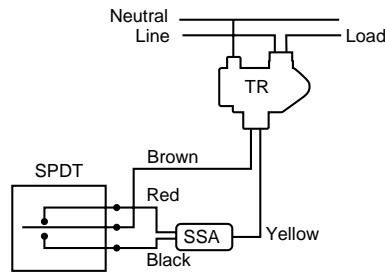

Figure 5

Installation: Figure 5 shows how the SSA is wired into a circuit to control a TR. The device is very flexible and installation in an existing switch enclosure should present no problem.

PCS Switch with a Pilot Light

The LED pilot light can be powered by two methods as shown in Figure 6. When only one ILC LED Assembly is used with a Transformer Relay and the distance between them is less than 40 feet, the TR can be used to power the LED.

The current draw will not cause the TR to switch. When two or more ILC LED Assemblies are being used, it is necessary to use a Pilot Light Power Supply (PLPS). This is a UL listed 10 VAC/10VA output transformer available with a 120 volt (PLPS-120) or 277 volt (PLPS-277) primary voltage. Because the LED draws current only on the half-cycle, the capacity of the PLPS can be maximized by alternating the polarity of the pilot light during installation (the blue and blue/white indicate the LED polarity). In this manner, the PLPS can power a maximum of 80 ILC LED Assemblies.

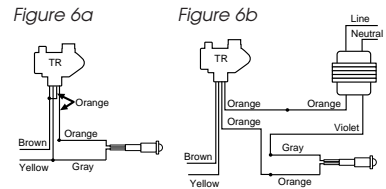

Master Control Switches and Interface Modules

To control more than one Transformer Relay from one switch or control point, it is necessary to use an Interface Module (IFM). Because each TR is a power source, each TR must be isolated by this patented diode array (Figure 7). If two or more TRs are wired in parallel without an IFM, they will fail to operate. Each IFM is designed to master interface up to 6 TRs. If more than six TRs are needed, the IFMs can be wired with parallel inputs.

The NFP Master Control Switch (NFP MCS) is designed to switch

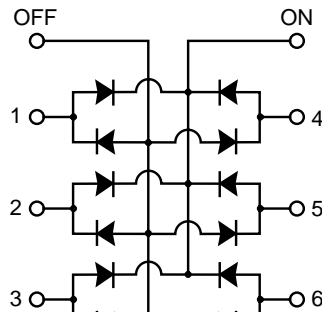
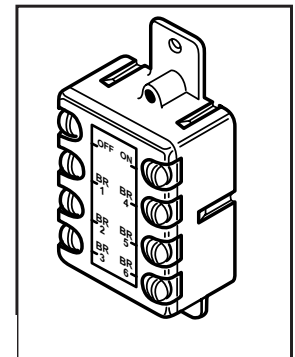

InterFace Module
U.S. Patent 4,364,314

Figure 7

the TRs connected to the IFM. The three wire switch is connected to the IFM with the ON side of the switch wired to the ON terminal, the OFF side of the switch wired to the OFF terminal and the yellow wire to the system common yellow.



Component Operational Summary

Magnetically Latched Transformer Relay

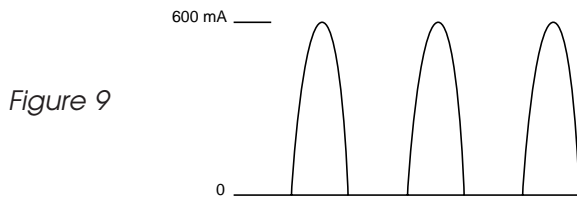
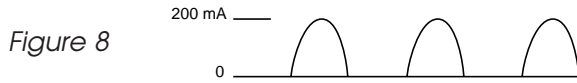

The number of TRs that can be controlled from an NFP MCS depends on the mixture of phase driving the mastered TRs. Figure 8 shows the half-wave, 200 mA current that a control switch must conduct. If three TRs on the same phase are connected to an IFM, the currents will add as shown in Figure 9. If the same three TRs were powered by three different phases, the currents in the NFP MCS control loop would sum up as in Figure 10.

Keeping in mind how the switching currents sum together, it is seen that using a balanced phase design is important. The 3 Amp rating on the NFP MCS would allow a maximum of 15 TRs on a single phase or 45 TRs on a balanced 3 phase system. To meet NEC requirements, the maximum current for a Class 2 circuit is 8 Amps. By using a heavy duty momentary contact SPDT switch, 40 TRs on a single phase could be mastered together (120 TRs on a 3 phase). By using a DPDT momentary contact switch with an 8 Amp rating, two separate systems could be mastered. When a control master is used, it is preferred that the distance between the IFM and the NFP MCS be minimized or the wire upsized because the current of each of the TRs is carried by the NFP MCS. This is appropriately reflected in the Applications Guide.

Note that the yellow wire from each of the components (TRs, NFP MCSs, etc.) are brought to a common connection. Figures 11 and 12 show two ways in which the yellow wires can be brought to a common point near the IFM. Figure 11 requires that the wire size of the common be increased as more TRs are added. Figure 12 is preferred —

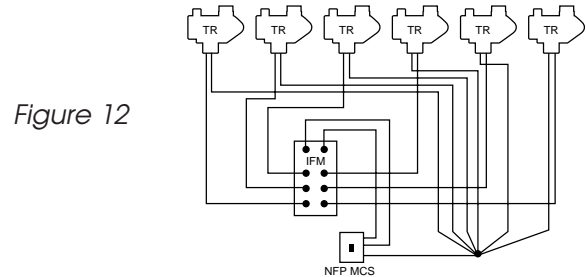
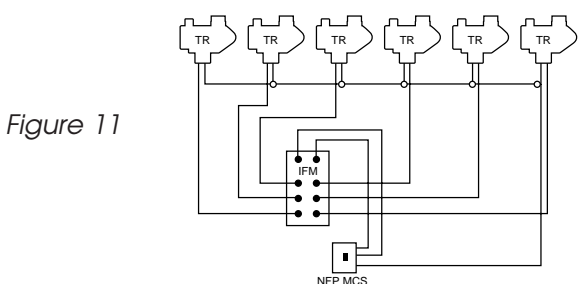

more wire is required, but only one connection is subject to a possible failure.

Interfacing with Maintained Contact Devices

The ILC Transformer Relay requires a momentary pulse to operate. Momentary contact switches must be used for both local and master control.

However, there are many control devices and sensors applicable to lighting and power control which have a maintained contact output. The Contact Interface (CIF) was designed to convert a maintained contact signal to a momentary contact signal, thus permitting the integration of such devices as time clocks, photo cells and microprocessors into the RCSS control network.

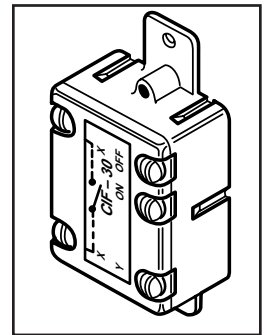

The CIF is an electronic device that emulates a momentary contact switch. The CIF circuitry draws a small amount of current from each Transformer Relay to which it is connected. This energy is stored in a capacitor until a maintained contact device (such as a time clock) causes the CIF to change switching states. When the maintained contact is closed, the CIF responds by allowing a 100 mSec current flow through the ON terminal. When the maintained contact is opened, the CIF allows a 100 mSec current to flow through the OFF terminal.

The CIF can be connected to one TR as shown in Figure 13 or to several TRs through IFMs as shown in Figure 14. when only one TR is connected to a CIF, the designer has

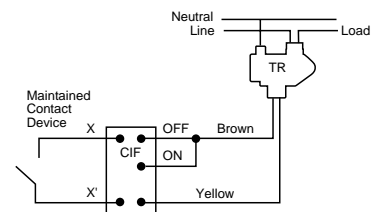



Component Operational Summary

Magnetically Latched Transformer Relay

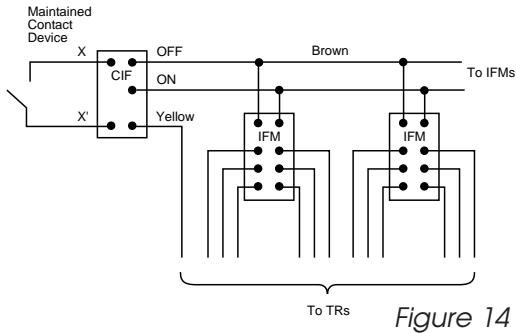

Figure 14

the option of connecting the TR brown wire to the ON, OFF, or to both terminals. Figure 13 shows how to wire a CIF so that a maintained contact device can switch a single TR both ON and OFF. However, when the CIF controls several TRs through an IFM, there must always be a connection between the OFF terminals of the CIF and the IFM as shown in Figure 14. This is because the CIFs internal capacitor is charged by the polarized current through the OFF terminal of the IFM.

As with any switching device, the CIF has a current limit. The circuit can handle up to 6 Amps. The CIF can control up to 30 TRs on a single phase since each TR contributes .2 Amps to the total current. If the designer distributes the TRs equally across all three places, the CIF can handle up to 90 TRs. For control of larger systems, up to 10 CIFs can be parallel wired at their inputs as shown in Figure 15.

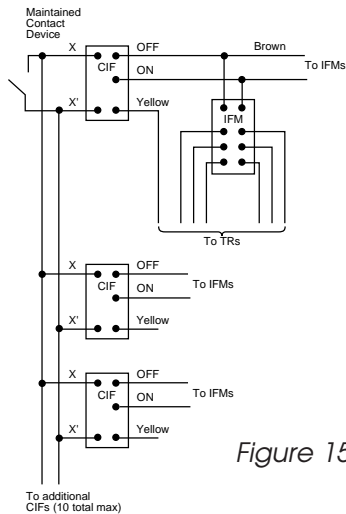

Figure 15

Because of their heat designation limits, there is a duty cycle associated with the CIF,

CIF Duty Cycle Limits

# of load per CIF	Maximum Switching Rate
1 TR.....	60 times/minute
2-9 TRs.....	10 times/minute
10+ TRs.....	6 times/minute