

# (FB) LL-EVO 1-Classroom, 3-Zone 1-Daylight Zone

## a - b - bc - c Lighting Zones, 3-Scene

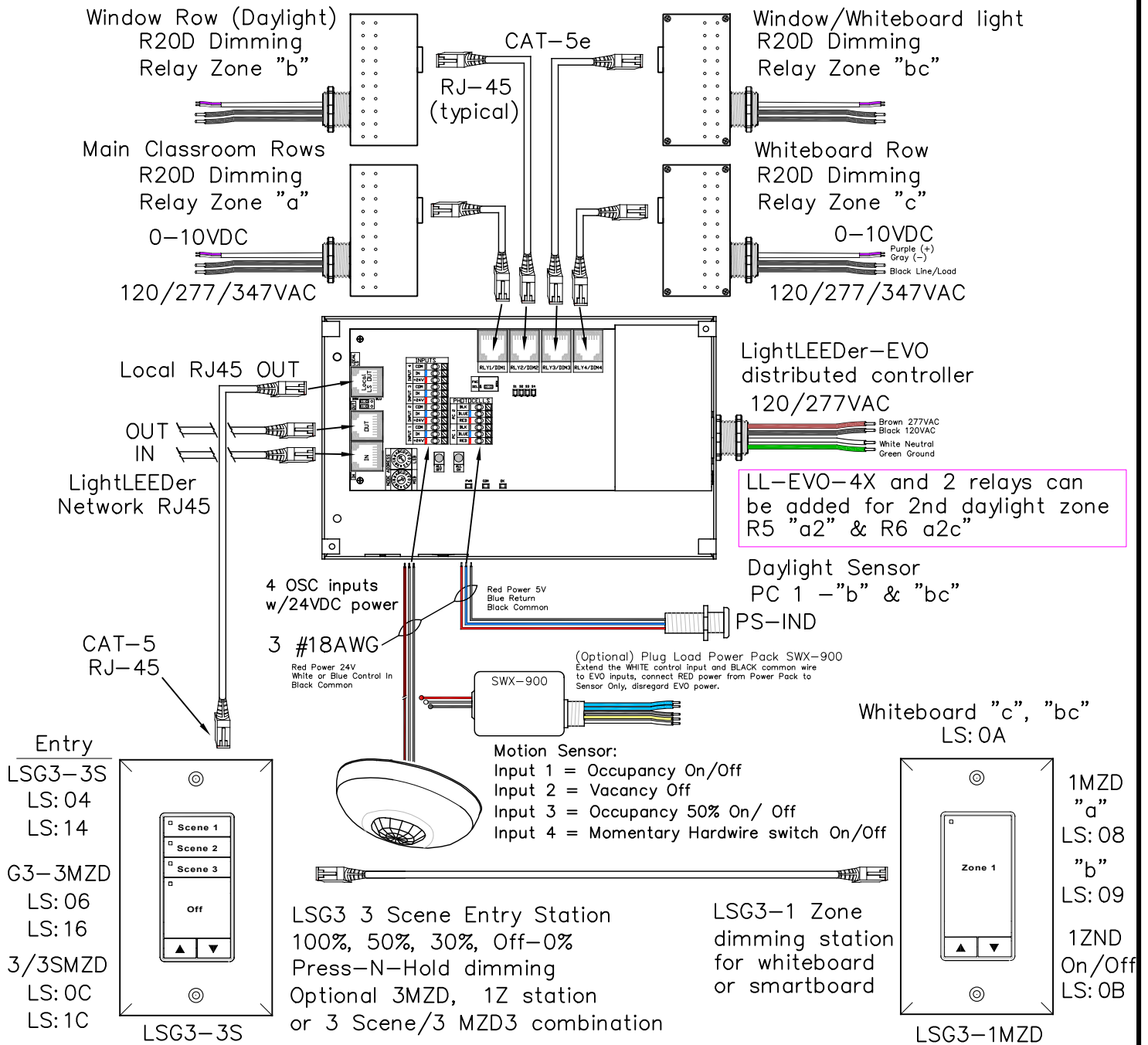

LightLEEDer EVO 4-Zone panel with 4-remotly mounted R20D relays  
Daylight sensor for window row lighting control, motion sensor inputs for Occupancy On/Off, Vacancy Off, Occ 50% On/Off or local hardwire switch.  
Local LightSync devices for Scene or MZD stations with raise/lower dimming All On/Off, and Whiteboard control. Supports up to 8 LightSync input devices.



5229 Edina Industrial Blvd.  
Minneapolis, MN 55439  
952.829.1900 | ilc-usa.com

Project:

(FB) LL-EVO Lighting Application Sheet  
1-Classroom, 3-Zone, 1-Daylight Zone  
"a", "b", "bc", "c" Lighting Zones, 3-scene  
LightLEEDer EVO Distributed Controller

SHEET INFORMATION

DATE: 2-20-2020

SCALE: NONE

DRAWN BY: JM

GO#

Sheet:

---

FB-EVO

Rev: C