



0-10V DIMMING WALL SWITCH SENSOR

LINE VOLTAGE



OVERVIEW

The **Intelligent Lighting Controls** family of wall switch occupancy/vacancy sensors provides a simple yet cost effective lighting control solution for many retrofit applications. Designed with contractors in mind, the **ILC 0-10V** dimming wall switch sensor is significantly shallower than typical dimmers and sensors, resulting in less crowded wall boxes. Additionally, versatile wiring enables usage with or without a neutral and allows reversal of line and load connections. **ILC** products utilize the latest passive infrared technology and digital signal processing techniques to provide unmatched motion detection performance. These units are also available with an integrated microphone to provide overlapping passive acoustic occupancy detection for rooms with obstructions or where occupant motion is limited. For dimming adjustment, intuitive raise and lower buttons are present in addition to an on/off button.

BASIC OPERATION

Sensors detect movement in the infrared energy that radiates from occupants as they move within the devices field-of-view. Once occupancy is identified, the sensor's internal relay switches power on to the connected lighting. All units can also be configured to operate in Vacancy Mode (e.g., require lights be manually switched on). Once lights are on and if equipped with passive dual technology (PIR/Acoustic), the unit's microphone is enabled to further enhance detection. An internal timer is set to keep lights on during brief periods of inactivity, and is reset every time occupancy is signaled by either the passive infrared or acoustic detection technologies. Ambient daylight detection can also be enabled in equipped units so that lights are held off in rooms with sufficient light contribution from windows or skylights.

SPECIFICATIONS

ELECTRICAL

OPERATING VOLTAGE
120/277 VAC, 50/60 Hz

LOAD RATINGS
MAX: 800W @ 120VAC
1200W @ 277VAC
MIN: None

LOAD TYPES
LED Driver/Lamps
CFL, Electronic/Magnetic Ballasts (Fluorescent)
Tungsten (Incandescent)

DIMMING COMPATIBILITY
0-10 VDC ballasts or drivers compliant
with IEC 60929 Annex E.2

DIMMING LOAD
- 50 mA (sink only)

ENVIRONMENTAL

OPERATING TEMP
32°F to 122°F (0°C to 50°C)

RELATIVE HUMIDITY
0-95% Non-Condensing,
Indoor Use Only

PHYSICAL

SIZE
2.74"H x 1.68"W x 1.39"D
(6.96 x 4.27 x 3.53 cm)
Not Including Mounting Strap

WEIGHT
4.5 oz

MOUNTING
Single Gang Switch Box



FEATURES

ELECTRICAL FEATURES

- Interchangeable Line & Load Wires - Impossible to Wire Backwards
- Accommodates Neutral (3-Wire) and No-Neutral (2-Wire) Installation
- Electronically Timed Switching Ensures Long Relay Life
- Compatible with 0-10V Dimmable LED, and Fluorescent Lighting
- Meets NEC Guidelines Regarding Current Leakage

PHYSICAL FEATURES

- Enclosure is 25-40% Shallower than Other Sensors (< 1" Depth into Wallbox)
- Unique Bat-Wing Shaped Lens Provides Enhanced Peripheral Detection
- Self-Grounding Mounting Strap
- Modern Look and Intuitive Easy-Tap Buttons for On/Off, Raise, & Lower
- Rugged Vandal Resistant Lens
- Settings are Adjustable Without Removing Cover Plate

OPERATIONAL FEATURES

- Wall-To-Wall Passive Infrared Small Motion Detection
- Passive Acoustic Detection (Optional) - Prevents False Offs when No Motion is Present
- 100% Passive Detection Methods - No Interference Potential from External Devices
- Configurable Sensor Settings Including Time Delays and Occupancy/Vacancy Operating Modes
- Configurable Dimming Parameters including High/Low Trims, Turn on Levels, and Curve Types
- Blue Locator LED when Lights are Off

WIRING

- Unit works both in installations where Neutral connection is available as well as installations where only Ground connection is present
- The unit's two black wires are interchangeable (e.g., one connects to line power, one connects to load)

STANDARD WIRING

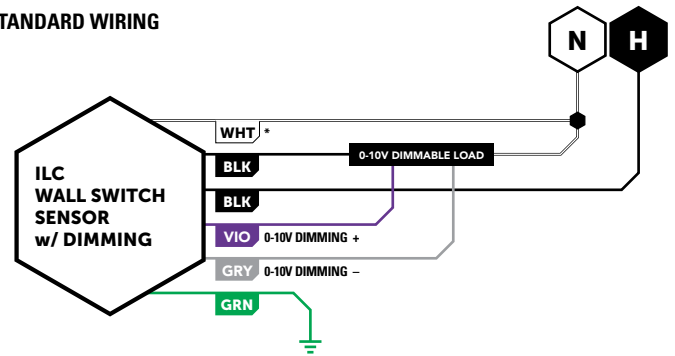

* NEUTRAL CONNECTION IS OPTIONAL, CAP IF UNUSED

3-WAY WIRING

TWO SENSORS IN PARALLEL

- Both Sensors Must Time Out for Lights to Turn Off
- Only one sensor can be model with 0-10V Dimming

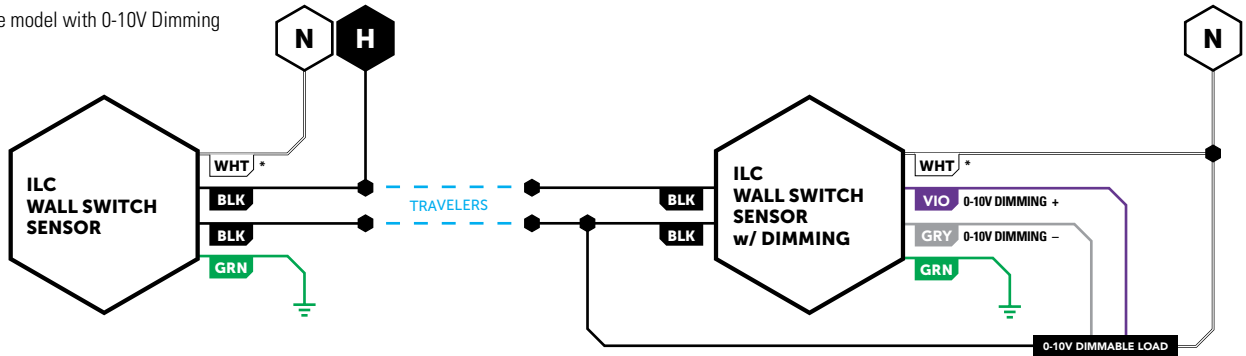

* NEUTRAL CONNECTION IS OPTIONAL, CAP IF UNUSED

INSTALLATION

FRONT

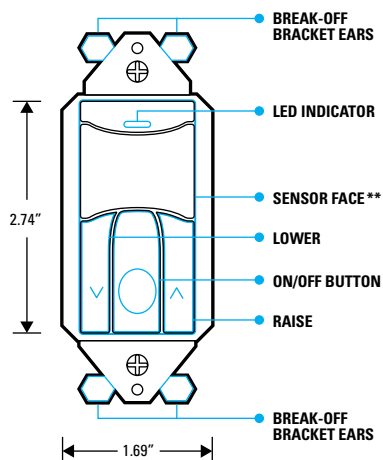

SIDE

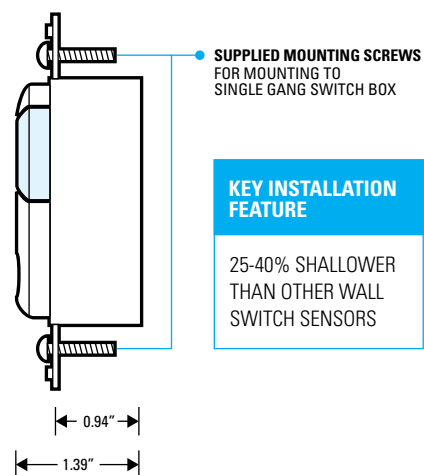

** SENSOR FACE IS FIELD REMOVABLE IN ORDER TO CHANGE COLORS. CONTACT FACTORY FOR ADDITIONAL FACES

OPERATION SETTINGS

TIME DELAY

- Test mode, 30 sec, 5-30 minutes
- 5 sec test mode expires after 10 minutes

HIGH-END & LOW-END TRIM

- High-end trim enables energy saving task tuning by setting a maximum level (100%-50%) that which users are allowed to raise lights
- Low-end trim enables minimum user level of dimmer to be raised

TURN ON/TURN OFF DIMMING OPERATION

- Sensor turns on lighting to last user level or a preset level (100%, 50%, or custom)
- Sensor can turn off lighting by switching off power (by opening relay) or dimming below electronic off level
- Lighting can also be held at low-end trim level during unoccupied/off state

FADE ON/FADE OFF TIMES

- Adjustable time for level to ramp up to turn-on level (0.75 sec, 1.5 sec, 3 sec, 5 sec, or 15 sec)
- Adjustable time interval for level to ramp down to off (0.75 sec, 1.5 sec, 3 sec, 5 sec, or 15 sec)

DIMMING CURVE

- The dimming curve defines how dimmers adjust their voltage output in response to button commands
- Linear (default), Square Law, Logarithmic

AMBIENT LIGHT (DAYLIGHT) DETECTION

- Sensor holds lights off when ambient light is present
- Manual threshold levels or auto-selection of threshold level
- Disabled when in Vacancy (Manual On) mode

TURN-ON SENSITIVITY

- When enabled, this setting reduces the sensor's PIR sensitivity for initial turn-ons in order to eliminate false on caused by reflective surfaces like windows
- Unit returns to full sensitivity after initial turn-on

OPERATIONAL MODES

ILC wall switch sensors are intelligent devices that provide both excellent energy savings and enhanced user convenience. Users can choose from several pre-programmed operational modes that best fit their preferences and applicable energy codes.

Vacancy Mode

Manual On / Automatic Off operation. Lights can also be switched off manually. This mode provides increased energy savings but requires the user to initially turn on the lights. Models ILC-SWX-103, ILC-SWX-104, ILC-SWX-123, and ILC-SWX-124 default to Vacancy modes.

Occupancy Mode

Automatic On and Automatic Off operation. If lights are switched off manually, the Automatic On functionality is temporarily disabled to allow the person a few seconds to leave the room before switching back to Automatic On operation. However, if the person remains in the space the unit will stay in a manual on state until the switch is pressed again. This mode is the default operation of ILC-SWX-101, ILC-SWX-111, ILC-SWX-121, and ILC-SWX-131 models.

Automatic On w/ Exit Time Mode

Automatic On and Automatic Off operation. If lights are switched off manually, the Automatic On functionality is disabled for a fixed 30 seconds.

Override Off Mode

Automatic On and Automatic Off operation until lights are switched off manually, at which point Automatic On functionality is disabled until the switch is pressed again.

Disabled Switch Mode

Automatic On and Automatic Off operation only. Switch functionality to manually turn on/off lights is disabled.

Presentation Mode

If lights are switched off manually, the Automatic On functionality is disabled until the space becomes unoccupied and the sensor's time delay expires.

LED FUNCTIONALITY

- White LED blinks upon occupancy detection
- Blue LED serves as a switch locator when lights are off
- LED functionality can be disabled