

## EPC-2

### Emergency Power Control For Switched Loads

Project:

Model No.:

Comments:



## MOUNTING

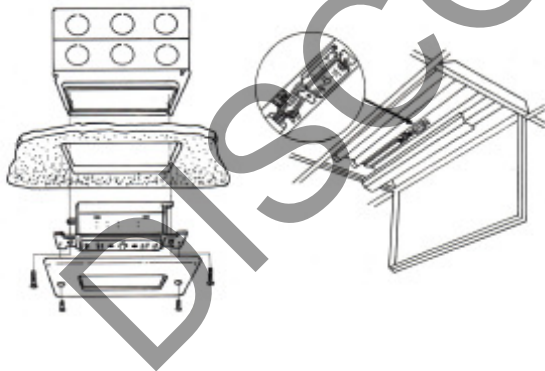

## APPLICATION

In the past, emergency lights were kept on 24 hours a day to meet life safety codes. Now, you can use a UL 924 listed Emergency Power Control, Model EPC-2, to convert regular light fixtures into approved emergency lights. The EPC-2 saves energy and money while ensuring compliance with both life safety and energy codes.

During normal operation, the same switch, occupancy sensor, relay panel, or lighting control can switch regular and emergency fixtures on and off simultaneously.

During a utility power interruption, the EPC-2 automatically bypasses the regular lighting controls, turning the emergency lights ON at full brightness, regardless of switch position.

The EPC-2 is ceiling or wall mounted in a junction box with a single gang plaster ring and is usually located in the area where the emergency fixtures are installed.

## FEATURES

- Unique, Patented Automatic Diagnostic  
When the room switch is turned off, the EPC-2 will run a 2.5 self-test routine, verifying that the emergency power source was available and that the EPC-2, ballast, and lamp(s) are all functioning correctly. This feature eliminates the need for time-consuming and costly manual monthly testing and is approved for this purpose. This also allows the unit to be installed in remote or inaccessible locations, because the unit does not rely on access to its manual test switch.
- Fire Alarm, Remote Test Options
- Utility & Emergency Power Indicator LED's
- Slim, attractive flush mount profile allows easy access to manual test switch and LED's.



INTELLIGENT LIGHTING CONTROLS, INC.

5229 Edina Industrial Boulevard  
Minneapolis, Minnesota 55439  
Phone 952 829 1900  
FAX 952 829 1901  
www.ilc-usa.com

## SINGLE LINE DRAWING

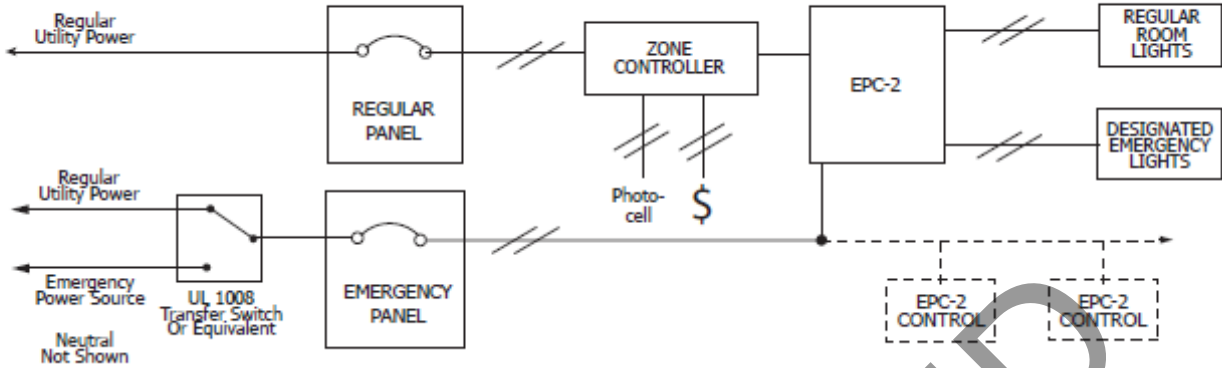

## WIRING DIAGRAM

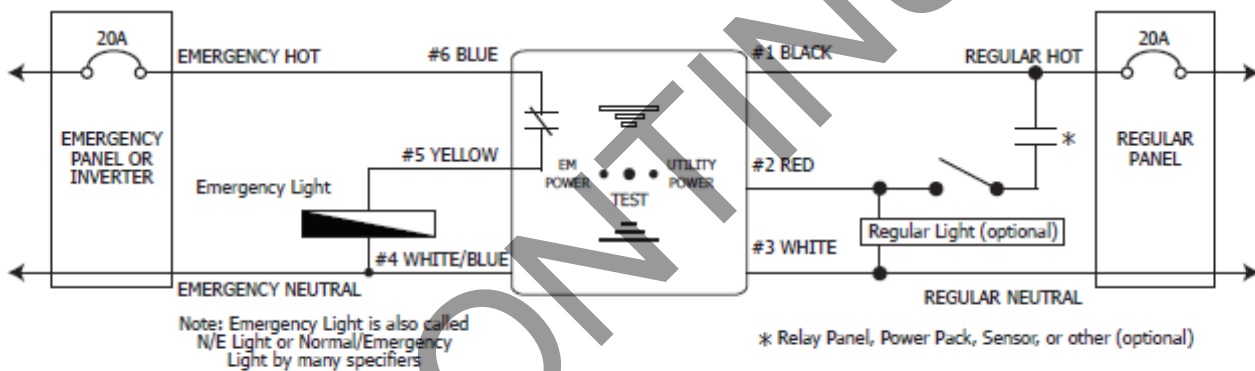

## SPECIFICATIONS

ELECTRICAL	MODEL NO.	EPC-2
	SENSING INPUT	120V - 277V
	LOAD RATING	120V - 277V (20A)
	BALLAST LOAD RATING	20A (120-277V)
	INCANDESCENT LOAD	1200W (120V) / 1500W (277V)
	WARRANTY	5 Year Replacement Warranty

MECHANICAL	MOUNTING	4-11/16" Junction Box w/ single gang plaster
	RATING	UL94-5VA
	SHIPPING WEIGHT / COLOR	12 oz. / White
	TEMPERATURE	32°F - 140°F (0°C - 60°C)
	FLUSH MOUNTED SIZE	Single Gang Plate
	BODY SIZE	1.7" x 3" x 1.2" (W x H x D body)

## ORDERING INFORMATION

EPC-2

## ADDITIONAL RESOURCES

- Installation Sheet
- FAQ Sheet
- Alternative Wiring Sheet
- Terms & Conditions/Warranty Information



INTELLIGENT LIGHTING CONTROLS, INC.

5229 Edina Industrial Boulevard  
 Minneapolis, Minnesota 55439  
 Phone 952 829 1900  
 FAX 952 829 1901  
 www.ilc-usa.com