

ILC **EcoSpec™ Linear Dimming Control Module**

Overview

ECOSPEC® Linear Dimming Control Module Plenum Rated (LDCM-PL) takes t 0-10v Dimming Signal and a Fixed Line Voltage Input and converts it to a Reverse Phase Dimmed Output for up to 1000W with a 277V load and 450W on a 120V load. One LDCM can be used per run up to the Maximum Wattage. The LDCM-PL is rated to directly mount to a junction box in a plenum space for easier installations and to meet building requirements.

ECOSENSE®



ECOSPEC™

Features

- Made in the USA
- Dims Reverse Phase Only Fixtures With 0-10V
- Simple Installation
- Direct J-Box Mount
- 120V and 277V Compatible
- Auto-Sensing Voltage Switch
- 450W @120V, 1000W @277V
- Plenum Rated
- One LDCM Per Fixture

Warranty

Five-year limited warranty

Ordering

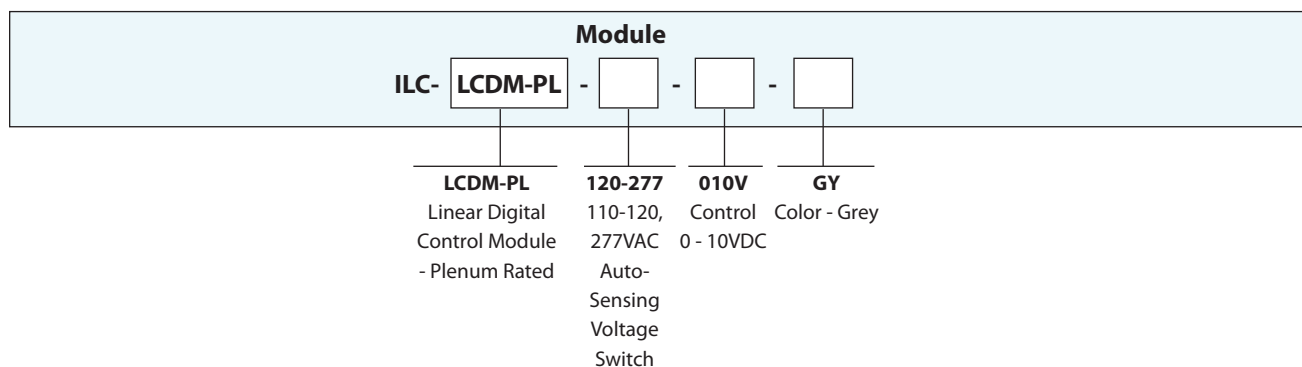

ILC

EcoSpec™ Linear Dimming Control Module

Physical

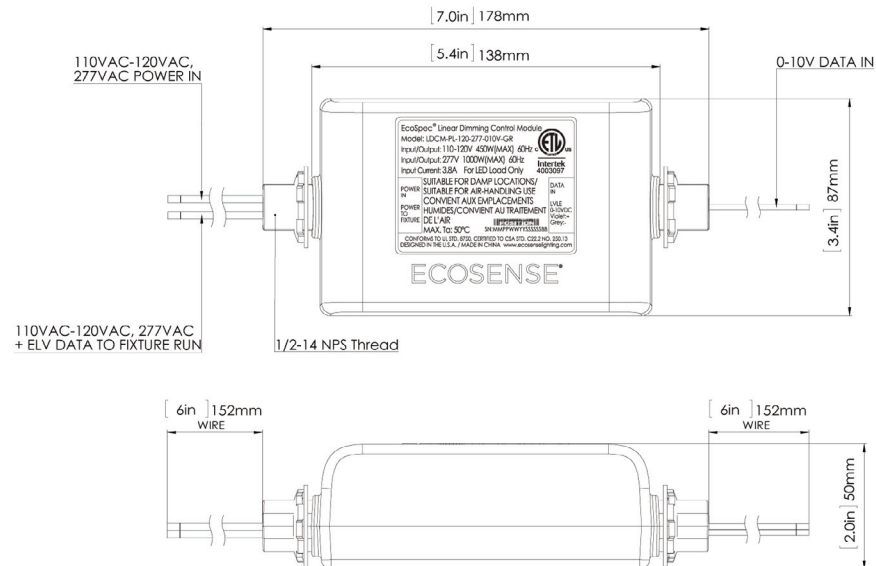

Specifications

Electrical:

- Power Rating - 450W MAX @ 110-120V, 1000W MAX @ 277V
- Max Fixture Run Length - calculate maximum run per LDCM unit based on the power consumption of the fixture use
- Operating Voltage - 110VAC-120VAC, 277VAC - Auto-Sensing Voltage Switch
- Operating Hertz - 60 Hz
- Startup Temperature: - 4°F TO 104°F (-20°C TO 40°C)
- Operating Temperature: - 4°F TO 104°F (-20°C TO 40°C)
- Storage Temperature: - 4°F TO 176°F (-20°C TO 80°C)

Control:

- 110-120/277VAC; Reverse Phase
- Dimming converted from 1-10V Controller

Physical:

- Dimensions - W 3.4" x H 2" x L 7"; (87mm x 50mm x 178mm)
Injection Molding
- Housing / Lens - Polycarbonate
- Connectors - Lead Wire 6" From Conduit
- Weight - 0.99 LBS (0.45 KG)
- Environment - ETL Damp Location
- Mounting Options - Conduit Mounting For Both Sides

Ratings & Certifications:

- ETL/cETL Damp Locations

