ILC Emergency Retrofit Insert Installation Guide

LLMRI Series

INTRODUCTION

The LightLEEDer Emergency UL 924 lighting controller provides emergency bypass operation for ILC's R40 relays. The LightLEEDer panel will be provided with UL 924 Relay Bypass Output Modules that will override the relays ON when normal power is lost to the panel. An optional Phase Monitoring Module can be added to the panel to monitor two or three-phase power when EM load relays are on more than one power phase of the emergency system. This configuration is used with a UL 1008 transfer switch operated by an emergency system providing back-up power.



IMPORTANT SAFEGUARDS

READ AND FOLLOW ALL SAFETY INSTRUCTIONS

CAUTION – The existing Lighting Control panel is fed from multiple circuit breakers or power sources. To reduce the risk of electrical shock, disconnect all power sources by turning off the A.C. branch circuit breaker before working on the ILC Retrofit panel upgrade

When using electrical equipment, basic safety precautions should always be followed, including those listed below:

- Read and follow all safety instructions
- Do not use outdoors
- Do not mount near gas or electric heaters
- Equipment should be mounted in locations and at heights where it will not be subject to tampering by unauthorized personnel
- The use of accessory equipment not recommended by the manufacturer may cause an unsafe condition
- Do not use this equipment other than its intended use
- If any Emergency Circuits are fed or controlled from this panel, it must be located electrically where fed from a UPS, generator, or other guaranteed source of power during emergency and power outage situations

SAVE THESE INSTRUCTIONS

Pre-Installation Inspection

- a. Check the Parts List and verify that all material has arrived in good condition and that no items are missing.
- b. Check the existing Lighting Control panel/s wiring to verify that no Line or Load wires are damaged. If damaged arrange for replacement wiring before installing the ILC panel upgrade hardware.
- c. Verify that Enclosure is UL Listed, Type 1 with the sizing of 20" H x 20" W x 7" D for up to a 24-relay controller, 27" H x 20.25" W x 7" D for a 32 or 40-relay controller and a 30" H x 24" W x 7" D for a 48-relay controller.
- d. Intended for installation within the enclosure of equipment listed for permanent installation.

Parts List:

1. LLMRI-XX-EM-NE (Emergency No Enclosure) Insert Assembly
2. Enclosure door #78001751 (24), 78001663 (32, 40) or 78001664 (48)
3. Tech Screws (8) #72159407
4. Door Screws (12) #72155046
5. Support Bracket Screws (4) #72153724
6. Support Brackets (2) #78001697
7. High Voltage Barrier (2) #78001696
8. Phase Monitor Barrier #78001650
9. High Voltage Divider (2) #78001750
10. Labels:
 - a. Suitable for Plenum #35400692
 - b. Caution Disconnect #35400388
 - c. SCCR #35400663
 - d. SCCR Warning #35400667
 - e. PMM #35400697

INSTALLATION INSTRUCTIONS

1. Power

Turn OFF all breaker panel circuits that are associated with the existing lighting control panel; test the panel wires with a voltage meter to ensure all circuits are off.

2. Remove existing hardware

- a. Remove connections on the primary leads of the existing transformer.
- b. Mark all Load/Line wires for future use and remove connections from existing relays.
- c. Locate (4) existing electronics mounting screws and remove backplate & controller/hardware.
- d. Remove upper protruding bolts from the existing enclosure and grind flush.



Figure 1

3. Install Emergency Retrofit Insert

- a. Remove relay barrier & support bracket from Retrofit assembly, set aside for later use.
- b. Mount retrofit assembly into the existing enclosure

- i. Use existing mounting bolts/holes when possible. Verify the minimum enclosure size matches pre-installation requirements. (See pre-installation inspection)
 - ii. Mount the retrofit assembly onto the existing lower bolts and secure the top of the backplate into the existing enclosure with (4) Tech Screws #72159407. Secure the bottom of the backplate with (2) additional Tech Screws #72159407.
 - iii. Secure the Phase Monitoring Backplate into the existing enclosure using (2) Tech Screws #72159407.
- c. Install Labels as shown:
- i. Caution Disconnect #35400388 (Figure 3)
 - ii. Plenum Rated #3540XXXX (Figure 3)
 - iii. SCCR #35400663 (Figure 2)
 - iv. SCCR Warning #35400667 (Figure 2)
 - v. PMM Inputs #35400697 (Figure 6)



Figure 2



Figure 3

- d. Install High Voltage Dividers as needed to separate Normal and Emergency loads; secure into the existing enclosure using (2) Tech Screws #72159407 (Figure 4)

Figure 4



- e. Reconnect existing Load & Line wires to individual relays as needed.
- f. Install Phase Monitor Module barrier by bending to form (Figure 5) and inserting between PMM and High Voltage section (Figure 6).

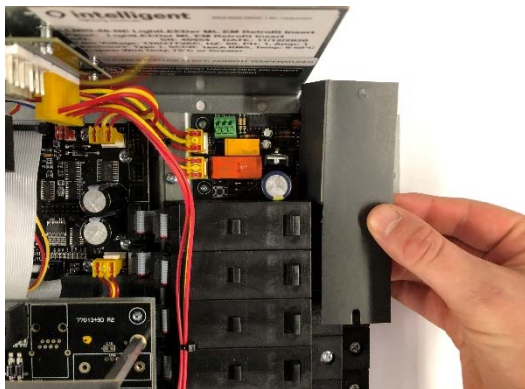

Figure 5



Figure 6

- g. Install support brackets and high voltage barrier using (2) #72153724 screws. (Figure 1)
- h. Verify correct RBOM jumper settings for all Normal & Emergency relays. EM relays should be set with the jumper "ON". (Figure 7)

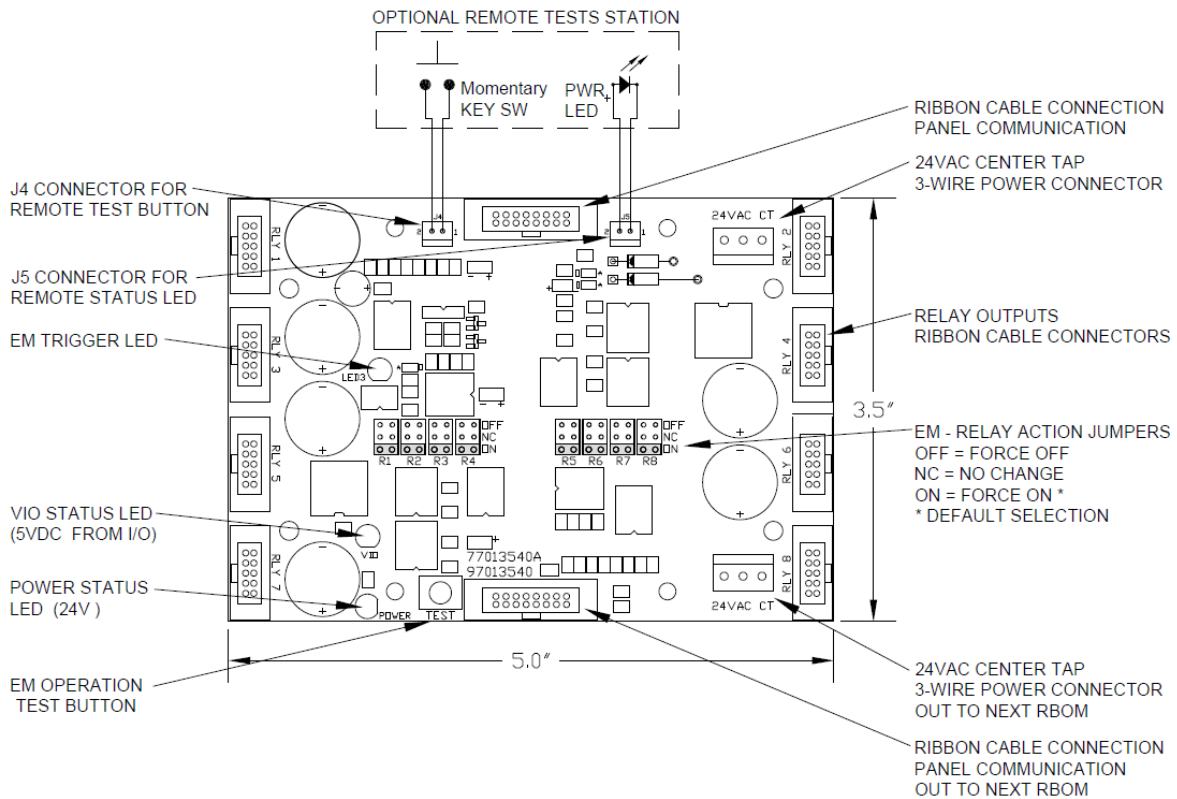

Figure 7 – RBOM Detail

i. Verify Factory Provided PMM Wiring connections:

- i. Transformer Power to “FROM TRX” terminal on PMM. (Figure 8)
- ii. “TO RELAYS” terminal (on PMM) to power distribution card. (Figure 8)
- iii. Power distribution card to Controller & First I/O Board. (Figure 9)



Figure 8

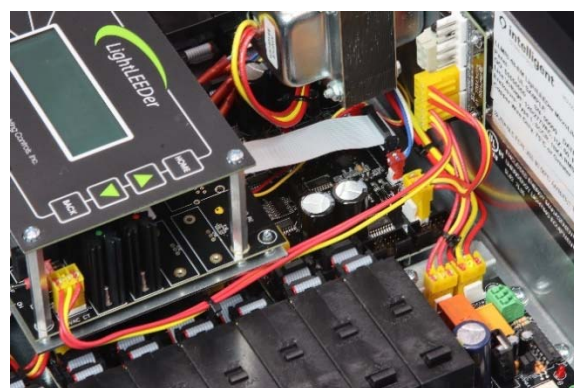

Figure 9

- iv. Normal, unswitched Phase “A” power will feed the panel transformer.
- v. Phase “B” & “C” unswitched normal power will connect to the PMM terminals, along with a power neutral. (Figure 10)

- vi. Verify the disable jumpers are removed for Phase "B" & "C" operation if applicable. (Figure 10)

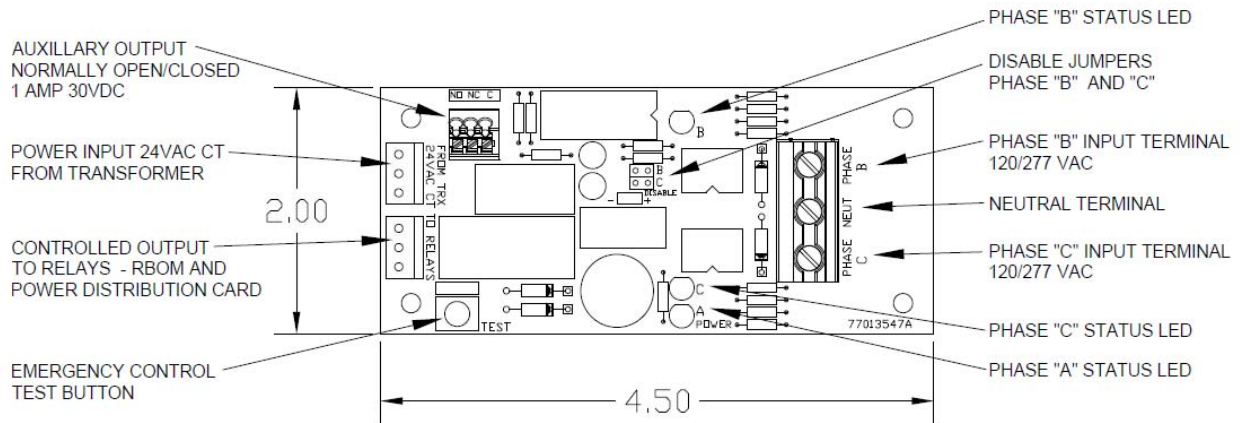

Figure 10 – Phase Monitoring Module

- j. Terminate primary leads of the new transformer to the existing high voltage circuit.
- k. Install provided LL Door (30" H x 24" W Door #78001664 shown in Figure 11) and secure with provided screw #72155046 (Figure 12)



Figure 11 - (30"H x 24"W Door #78001664 Shown)



Figure 12

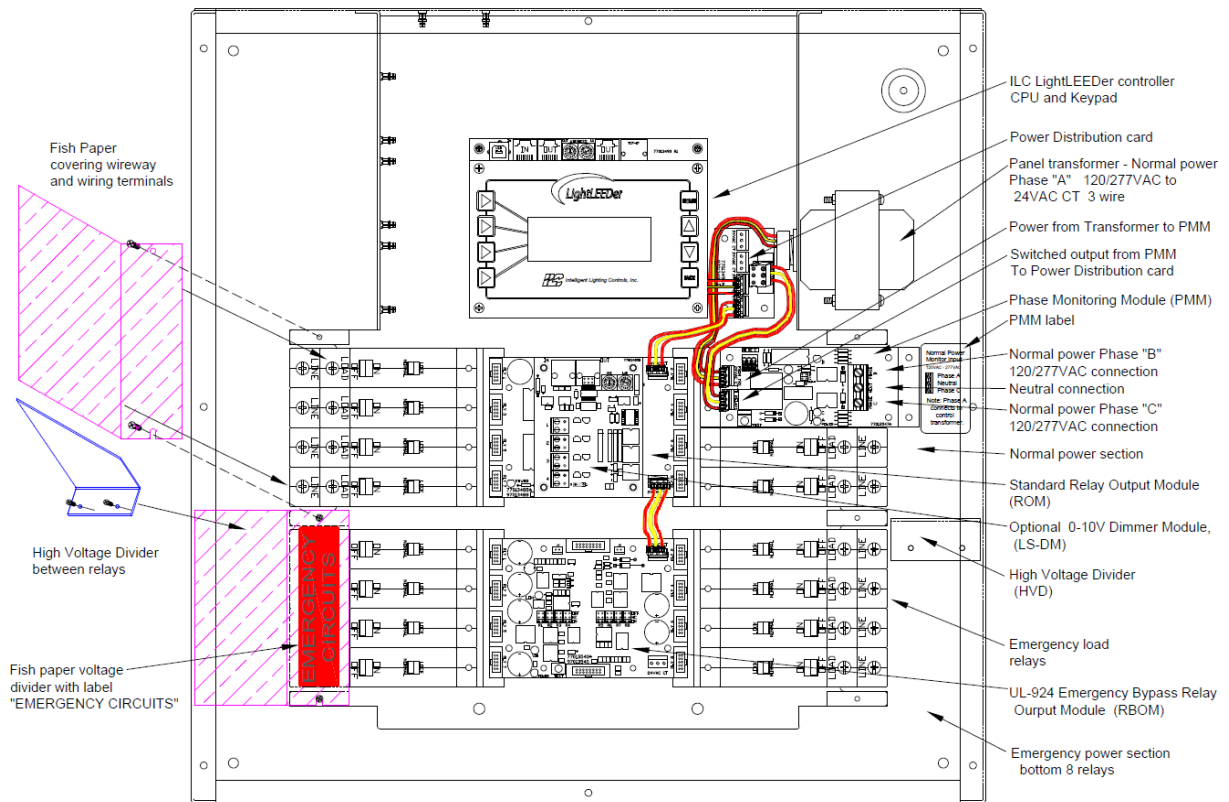

Figure 13 – Generic ILC Emergency Panel Detail

4. Test Phase Monitoring Module & Emergency Operation

- a. Verify that all safety instructions & inspections from page 2 have been completed before powering and testing the ILC panel.
- b. Cycle each Phase and ensure that PMM triggers the emergency loads when power is lost on any phase. All Relays should fire into the ON, OFF, or remain in the current state as indicated by their respective RBOM jumpers. - Verify that the A, B, & C phase status LED's on the PMM emulate panel operation. (Figure 10)
- c. Use Emergency Control Test Button (located on Phase Monitor Module) to momentarily force Emergency operation. Note that when using the Test Button or Remote Testing switch, the power to the CPU & LightSync Devices will remain on. (Figure 10)

5. Code-Required Testing

- a. NFPA requires the testing of emergency lighting equipment be performed monthly. ILC recommends following all requirements for monthly testing, and record keeping. Refer to NFPA section 7.9.3 for details and requirements.

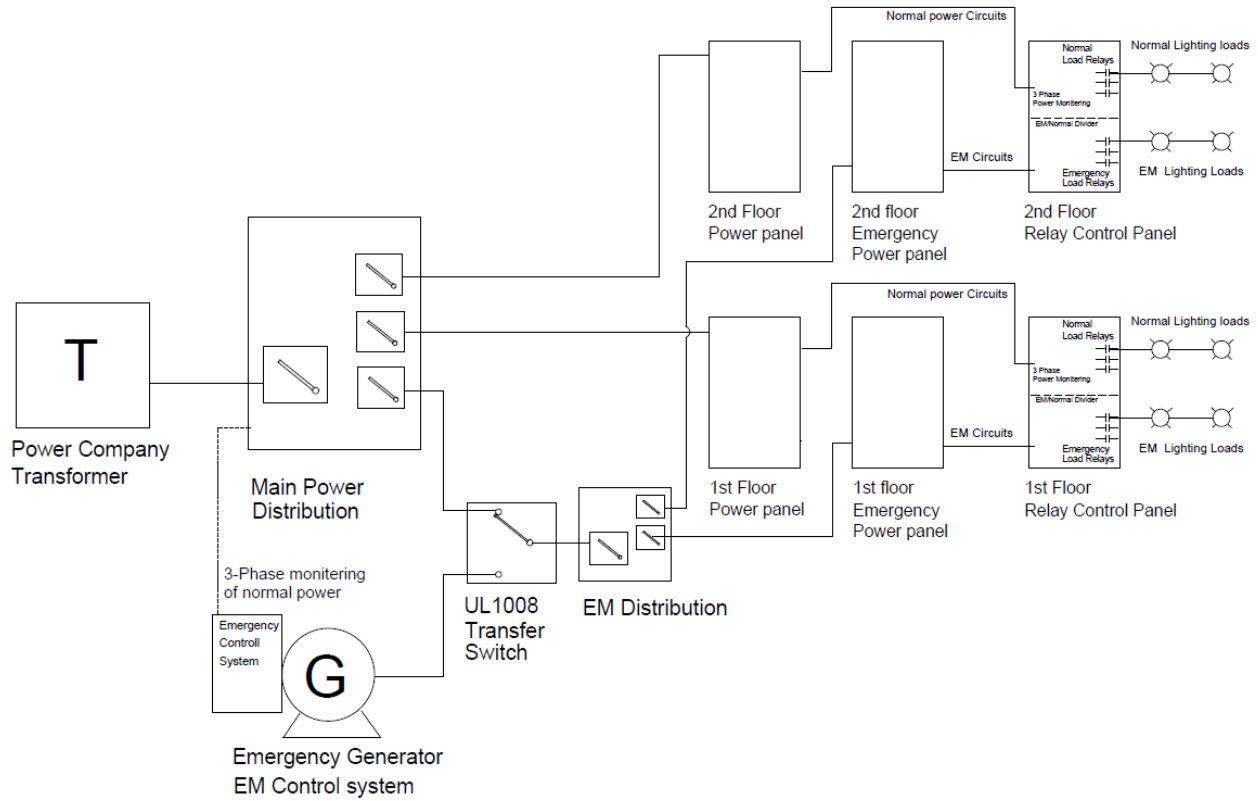

Figure 14 – Code Testing Detail