



WALL SWITCH OCCUPANCY SENSOR

LINE VOLTAGE



SENSORWORX®

OVERVIEW

The **SENSORWORX** family of wall switch occupancy sensors provides a simple yet cost effective lighting control solution for many retrofit applications. Designed with contractors in mind, the **SENSORWORX** wall switch sensor is significantly shallower than typical sensors, resulting in less crowded wall boxes. Additionally, versatile wiring enables usage with or without a neutral and allows reversal of line and load connections. **SENSORWORX** products utilize the latest passive infrared technology and digital signal processing techniques to provide unmatched motion detection performance. These units are also available with an integrated microphone to provide overlapping passive acoustic occupancy detection for rooms with obstructions or where occupant motion is limited.

BASIC OPERATION

Sensors detect movement in the infrared energy that radiates from occupants as they move within the devices field-of-view. Once occupancy is identified, the sensor's internal relay switches power on to the connected lighting. Units can also be configured to operate in Vacancy Mode (e.g., require lights be manually switched on). Once lights are on and if equipped with passive dual technology (PIR/Acoustic), the unit's microphone is enabled to further enhance detection. An internal timer is set to keep lights on during brief periods of inactivity, and is reset every time occupancy is signaled by either the passive infrared or acoustic detection technologies. Ambient daylight detection can also be enabled in equipped units so that lights are held off in rooms with sufficient light contribution from windows or skylights.

SPECIFICATIONS

ELECTRICAL

OPERATING VOLTAGE

120/277 VAC, 50/60 Hz

LOAD RATINGS

MAX: 800W @ 120VAC

1200W @ 277VAC

MIN: None

LOAD TYPES

LED Driver/Lamps

CFL, Electronic/Magnetic Ballasts (Fluorescent)

Tungsten (Incandescent)

ENVIRONMENTAL

OPERATING TEMP

32°F to 122°F (0°C to 50°C) - Standard

-40° F/C (with **-HE** Option)

RELATIVE HUMIDITY

0-95% Non-Condensing,

Indoor Use Only

PHYSICAL*

SIZE

2.74"H x 1.68"W x 1.39"D

(6.96 x 4.27 x 3.53 cm)

Not Including Mounting Strap

WEIGHT

4.5 oz

MOUNTING

Single Gang Switch Box

*2-POLE SOLUTION INCLUDES TWO UNITS
(e.g., 2X SIZE, WEIGHT, MOUNTING)



FEATURES

ELECTRICAL FEATURES

- Interchangeable Line & Load Wires - Impossible to Wire Backwards
- Accommodates Neutral (3-Wire) and No-Neutral (2-Wire) Installation
- Electronically Timed Switching Ensures Long Relay Life
- Compatible with LED, Fluorescent and Incandescent Lighting
- Meets NEC 404.2(c) & 404.22 Guidelines Regarding Powering Over Ground & Current Leakage

PHYSICAL FEATURES

- Enclosure is 25-40% Shallower than Other Sensors (< 1" Depth into Wallbox)
- Unique Bat-Wing Shaped Lens Provides Enhanced Peripheral Detection
- Self-Grounding Mounting Strap
- Modern Look and Intuitive Easy-Tap Button
- Rugged Vandal Resistant Lens
- Settings are Adjustable Without Removing Cover Plate

OPERATIONAL FEATURES

- Wall-To-Wall Passive Infrared Small Motion Detection
- Passive Acoustic Detection (Optional) - Prevents False Offs when No Motion is Present
- 100% Passive Detection Methods - No Interference Potential from External Devices
- Ambient Daylight Override Mode Increases Energy Savings (Optional)
- Configurable Time Delays and Operating Modes
- Blue Locator LED when Lights are Off

COVERAGE PATTERNS

- 30" to 48" (0.76 - 1.22 m) recommended mounting height
- Wall to wall (~180 degree) coverage
- Small motion (e.g., hand movement) detection up to 20 ft (6.10 m), ~625 ft²
- Large motion (e.g., walking) detection greater than 36 ft (10.97 m), ~2025 ft²
- Overlapping acoustic detection of occupants over entire coverage area
- Advanced signal processing filters out nuisance noises while not effecting overall sensitivity

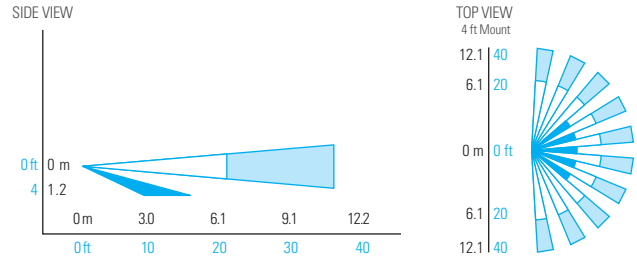

APPLICATIONS

A wall switch sensor is typically used to retrofit an existing wall switch in a small room or enclosed space. A Passive Infrared (PIR) only sensor is sufficient for spaces where line of site is maintained and occupants are periodically moving (e.g., copy rooms, storage rooms). Dual technology sensors are necessary where occupants may be partially blocked from the sensor's direct view or where they may be stationary (e.g., private offices or restrooms with stalls).

- Private Restrooms
- Small Office
- Copy Rooms
- Vestibule
- Restroom with Stalls
- Storage Room
- Small Meeting Room
- Break Room

✓ CODE COMPLIANCE

Wall Switch sensors can be used to meet many requirements of ASHRAE 90.1 (2016), IECC (2015), and Title 24 (2016).

COMMON ENERGY CODE DEFINITIONS:

- Occupancy Operation: Auto On/Auto Off
- Vacancy Operation: Manual On/Auto Off
- Partial On Operation:
 - 1st Pole Auto On / 2nd Pole Manual On
 - Auto On to 50% / Manual On to 100%
 - All Poles Auto Off

ASHRAE®
STANDARD 90.1 - 2016

IECC®
2015 STANDARD



MULTI-GANG SWITCH REPLACEMENT

Many residential and commercial building spaces contain multi-gang switch locations (i.e. locations on the wall that have more than one single-gang switch devices in the same wall box). The **SENSORWORX** solution for these applications utilizes a wall switch occupancy sensor and one or more added "sidecar" wall switches that receives necessary occupancy information from the adjacent sensor. Each unit can be configured separately for Auto On or Manual On (Vacancy) operation and time delay. Most conveniently, this solution enables adding a standard multi-gang decorator switch plate in order to provide an aesthetically pleasing appearance without any awkward and conspicuous blank wall plate sections. Additional sidecar switches can also be added to create 3-pole (or greater) solutions.

INBOARD / OUTBOARD SWITCH REPLACEMENT

Many older buildings have fluorescent light fixtures wired for inboard/outboard control by a pair of wall switches. Retrofitting these wall switches with code-compliant controls is attractively done with a **SENSORWORX** 2-pole solution (model: #SWX-102 or SWX-122). These two unit kits contain an Auto On occupancy sensor and a Manual On sidecar switch that work together to meet the required partial on energy code requirements.

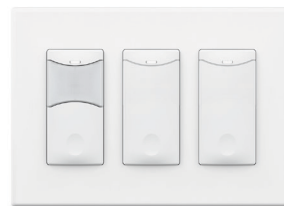

BATHROOM LIGHTS & FAN

Bathrooms often have separate switches for lights and ventilation fans. In some cases two switches for lights (e.g. vanity and shower) and the fan are all contained in the same 3-gang wall box along the entry wall. Retrofitting these switches with a **SENSORWORX** wall switch sensor and two sidecar switches is an attractive and energy efficient solution for providing occupancy control of all three loads.



ORDERING INFO

SAMPLE MODEL # SWX-101-WH

	PRODUCT	DETECTION	# of POLES / DEFAULT OPERATION	COLOR*	ADDITIONAL OPTIONS					
SWX	Wall Switch Sensor	1	Passive Infrared (PIR)	0	1-Pole: Auto On (Occupancy)	1	White	- WH	None	Blank
		2	Passive Infrared (PIR) + Daylight	1	2-Pole: Partial On†	2	Ivory	- IV	Humid Environment	- HE
		3	Passive Dual Technology (PIR/Acoustic)	2	1-Pole: Manual On (Vacancy)	3	Light Almond	- LA	10 Pack**	- J10
		4	Passive Dual Technology (PIR/Acoustic) + Daylight	3	1-Pole: Vacancy Only (CA Title 20/24)	4	Gray	- GY		

*WALLPLATE NOT INCLUDED

** THE CONTRACTOR PACK OPTION (-J10) REDUCES JOB SITE WASTE AND INVENTORY TIME (AVAILABLE FOR SINGLE POLE MODELS ONLY)
 † 2-POLE SOLUTION INCLUDES A SINGLE POLE OCCUPANCY SENSOR AND A CONNECTED "SIDECAR" SWITCH UNIT FOR SECOND POLE (REQUIRES TWO GANG BOX)

ACCESSORY	COLOR
SWX-831-SC Additional Sidecar Switch Unit (for use with SWX-1x2 Kits)	White - WH
SWX-199 Single Gang Wall Plate	Ivory - IV
SWX-199-FACE Sensor Face Color Change Kit	Light Almond - LA
	Gray - GY
	Black - BK
	Red - RD

WIRING

- Unit works both in installations where neutral connection is available as well as installations where only ground connection is present.
- If no neutral is present, remove the white sleeve from the wire & connect the now Green/Yellow wire to ground (see diagram below).
- The White wire (or Green/Yellow wire underneath the removable sleeve) MUST be connected to neutral (or Ground if sleeve is removed) for the unit to operate.
- The all Green wire is just for safety.
- The unit's two black wires are interchangeable (e.g., one connects to line power, one connects to load).

STANDARD WIRING

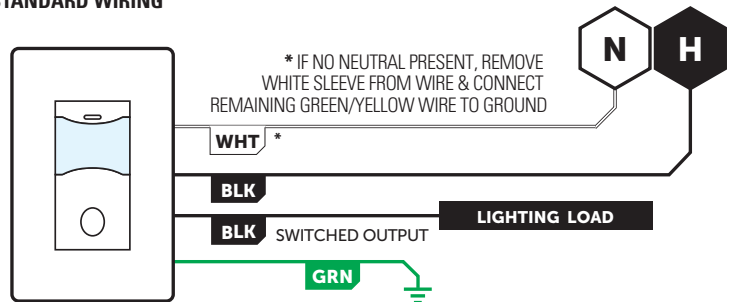

NEUTRAL TO GROUND WIRE CONVERSION DETAIL

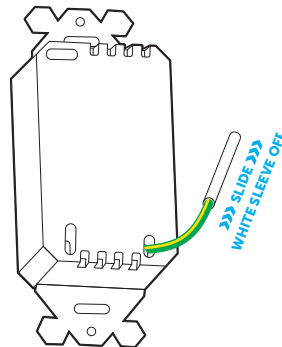

NOTE: This product is UL listed and meets NEC 404.2(c) & 404.22 guidelines regarding powering over ground & current leakage. Powering over ground is permitted for replacement / retrofit only.

3-WAY WIRING

TWO SENSORS IN PARALLEL

- Both sensors must time out for lights to turn off (or both buttons must be switched)
- Recommended for Automatic On (Occupancy) applications only

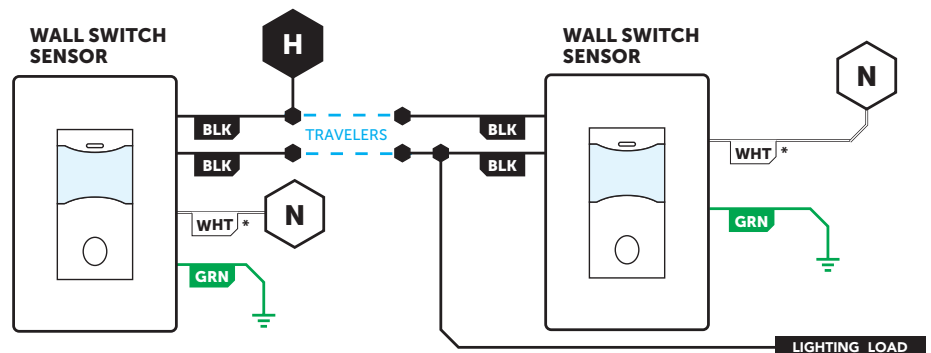

* IF NO NEUTRAL PRESENT, REMOVE WHITE SLEEVE FROM WIRE & CONNECT REMAINING GREEN/YELLOW WIRE TO GROUND

2-POLE WIRING

- 2-Pole solution includes a single pole occupancy sensor and a connected "sidcar" switch unit for second pole
- Requires two-gang box and decorator wall plate.
- Units can be powered from same or different circuits/voltages.

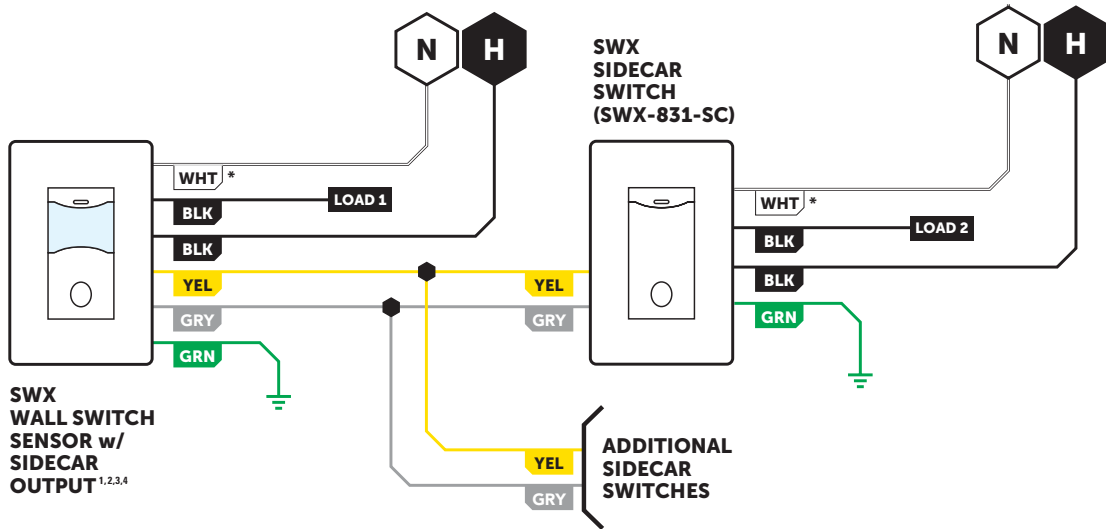

* IF NO NEUTRAL PRESENT, REMOVE WHITE SLEEVE FROM WIRE & CONNECT REMAINING GREEN/YELLOW WIRE TO GROUND

¹ MODEL NUMBER SWX-102 INCLUDES UNIT SWX-101-SC AND SWX-831-SC
² MODEL NUMBER SWX-112 INCLUDES UNIT SWX-111-SC AND SWX-831-SC
³ MODEL NUMBER SWX-122 INCLUDES UNIT SWX-121-SC AND SWX-831-SC
³ MODEL NUMBER SWX-132 INCLUDES UNIT SWX-131-SC AND SWX-831-SC

INSTALLATION

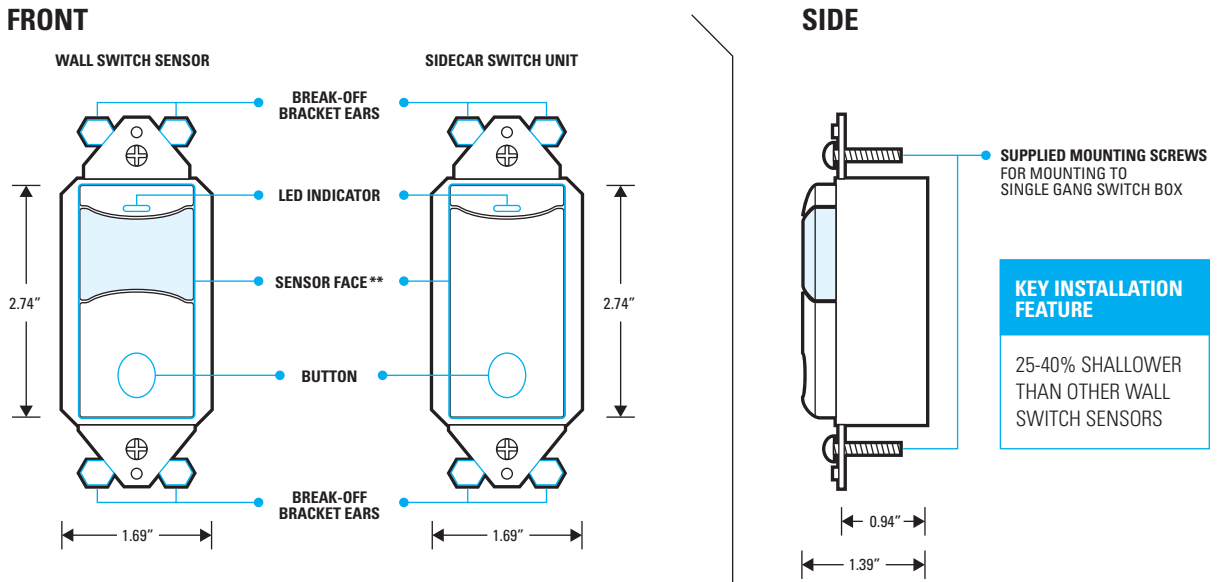

** SENSOR FACE IS FIELD REMOVABLE IN ORDER TO CHANGE COLORS. CONTACT FACTORY FOR ADDITIONAL FACES

OPERATION SETTINGS

TIME DELAY

- Test Mode, 30 sec, 5-30 min
- Both master wall switch sensor unit and sidecar switch unit in 2-Pole solution have independent time delay

AMBIENT LIGHT (DAYLIGHT) DETECTION

- Sensor holds lights off when ambient light is present
- Manual threshold levels or auto-selection of threshold level
- Disabled when in Vacancy (Manual On) mode

TURN-ON SENSITIVITY

- When enabled, this setting reduces the sensor's PIR sensitivity for initial turn-ons in order to eliminate false on caused by reflective surfaces like windows
- Unit returns to full sensitivity after initial turn-on

LED FUNCTIONALITY

- White LED blinks upon occupancy detection
- Blue LED serves as a switch locator when lights are off
- LED functionality can be disabled

OPERATIONAL MODES

SENSORWORX wall switch sensors are intelligent devices that provide both excellent energy savings and enhanced user convenience. Users can choose from several pre-programmed operational modes that best fit their preferences and applicable energy codes. Note that both the master wall switch sensor unit and sidecar switch unit in 2-Pole solution (SWX-102, SWX-122) have independent operational modes.

Vacancy Mode

Manual On / Automatic Off operation. Lights can also be switched off manually. This mode provides increased energy savings but requires the user to initially turn on the lights. Models SWX-103, SWX-104, SWX-123, and SWX-124 default to Vacancy modes. Sidecar switch units (SWX-831-SC) in 2-Pole kits also default to Vacancy mode.

Occupancy Mode

Automatic On and Automatic Off operation. If lights are switched off manually, the Automatic On functionality is temporarily disabled to allow the occupant a few seconds to leave the room before returning to Automatic On operation. However, if the person remains in the space, the unit will stay in a manual on state until the switch is pressed again. This mode is the default operation of SWX-101, SWX-111, SWX-121, and SWX-131 models.

Automatic On w/ Exit Time Mode

Automatic On and Automatic Off operation. If lights are switched off manually, the Automatic On functionality is disabled for a fixed 30 seconds to allow a person time to leave the room.

Override Off Mode

Automatic On and Automatic Off operation until lights are switched off manually, at which point Automatic On functionality is disabled until the switch is pressed again.

Disabled Switch Mode

Automatic On and Automatic Off operation only. Switch functionality to manually turn on/off lights is disabled.

Presentation Mode

If lights are switched off manually, the Automatic On functionality is disabled until the space becomes unoccupied and the sensor's time delay expires.

