

MODELS

MODEL #	PIR	ACOUSTIC	PHOTOCELL	LENS TYPE
ILC-SWX-401-1	•			WIDEVIEW
ILC-SWX-411-1	•		•	WIDEVIEW
ILC-SWX-421-1	•	•		WIDEVIEW
ILC-SWX-431-1	•	•	•	WIDEVIEW
ILC-SWX-402-1	•			HALLWAY
ILC-SWX-412-1	•		•	HALLWAY

ADDITIONAL UNIT OPTIONS

- **AR:** Isolated Auxiliary Relay
- **HE:** Humid Environment

FEATURES

- **Digital Passive Infrared (PIR) Detection**
- **Passive Acoustic Detection (Optional)**
- **Wide View (120°) or Hallway (Long Range) Coverage Pattern Options**
- **Compact Size and Matte Finish**
- **Five Contractor Friendly Mounting Methods**
- **Mounting Nipple Attachment with Integrated Hole Saw**
- **Convenient Test Mode and Adjustable Time Delays**
- **Optional Ambient Light Override (Photocell)**

SPECIFICATIONS

ELECTRICAL

OPERATING VOLTAGE

12-24 VAC/VDC

CURRENT DRAW

2mA (PIR models)
16mA (Dual Tech. models)
18mA (Dual Tech. w/ Photocell models)

OUTPUT

Logic High VDC (Occupied Mode)

RECOMMENDED POWER PACK

(e.g., ILC-SWX-900)

ISOLATED RELAY RATING

1A @ 30 VDC/VAC

ENVIRONMENTAL

OPERATING TEMP

32° to 122°F (0° to 50°C) - Standard
-40° F/C (with **-HE** option)

RELATIVE HUMIDITY

0-95% Non-Condensing,
Indoor Use Only

ROHS COMPLIANT

PHYSICAL

SIZE

2.875" H x 2.75" W x 3.25"D
(7.30 x 6.98 x 8.25 cm)

WEIGHT

4.75 oz.

COLOR

White

OPERATION

TIME DELAYS

30 sec. to 30 min. (Typical)
10 Minute Default
5 sec. Test Mode

CODE COMPLIANCE

Sensors can be used to meet ASHRAE 90.1, IECC, & Title 24 energy code requirements



OVERVIEW

Sensors detect movement in the infrared energy that radiates from occupants as they move within the devices field-of-view. Once occupancy is identified the sensor signals a connected power/relay pack to switch on the connected lighting. If equipped with passive dual (PIR/Acoustic) technology, the unit's microphone is then also enabled to further enhance detection while the lights are on. An internal timer is set to keep lights on during brief periods of inactivity, and is reset every time occupancy is signaled by either the passive infrared or acoustic detection technologies. Additionally, optional daylight detection is available that will turn off controlled lighting whenever there is sufficient ambient light in the space.

APPLICATIONS

A single sensor may provide sufficient coverage in many spaces, however, multiple low voltage sensors can be easily wired together to provide improved coverage for large or irregular shaped spaces.

- Classrooms
- Open Areas
- Large Offices
- Conference Rooms
- Hallways/Corridors

COVERAGE PATTERN

PASSIVE INFRARED (PIR)

WIDE VIEW 120°

- Small motion (e.g., hand movements) detection up to 40 ft (12.19 m)
- Large motion (e.g., walking) detection up to 70 ft (21.34 m)
- Designed for 8 to 12 ft (2.44 to 3.66 m) high mounting

SIDE VIEW

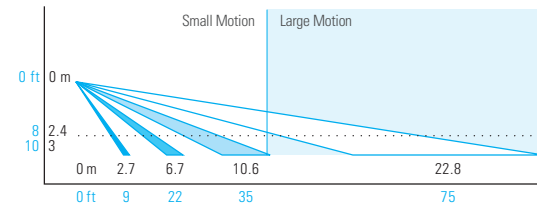

TOP VIEW

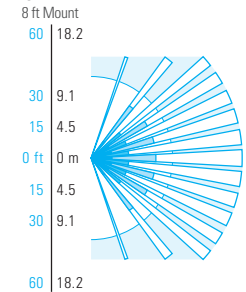
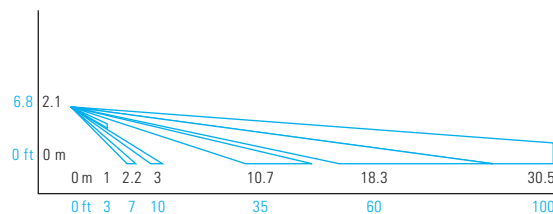

Diagram reflects sensor in first position. Adjust angle downward if mounting above 10 feet or to decrease gap directly under sensor.

HALLWAY (LONG RANGE)

- Designed for 8 to 12 ft (2.44 to 3.66 m) high mounting
- Large motion (e.g., walking) detection up to 100 ft (30.48 m)
- Detection occurs sooner when crossing coverage beams upon entry to a hallway as opposed to entering from the end and walking directly at the sensor

SIDE VIEW



TOP VIEW

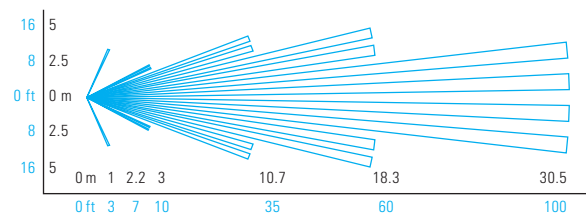

DUAL TECHNOLOGY (PIR/ACOUSTIC)

- Units with dual technology (ILC-SWX-421-1 and ILC-SWX-431-1) have overlapping acoustic detection of the complete PIR coverage area.
- A PIR event is required to initially enable acoustic detection
- Sounds indicating occupancy reset the sensor's time delay while non-occupant noises are filtered out
- Occupant sounds alone will not keep lights on indefinitely, PIR motion must be periodically detected for lights to remain on for an extended time
- After sensor time out expires, acoustic detection remains enabled for 10 seconds to enable voice reactivation of lights for additional convenience and safety
- Not available on units with Hallway (Long Range) lens

AMBIENT LIGHT OVERRIDE (PHOTOCELL) OPERATION

Sensors with an integrated photocell will turn lights on/off depending on the amount of ambient light detected. This operation makes them ideal for lighting near skylights or windows.

WIRING

- Apply power to connected power packs only after low voltage sensor connections have been made.
- Wiring sensors to a live power pack is not recommended, although in cases where required, it is recommended that the red wire be connected last.

STANDARD WIRING

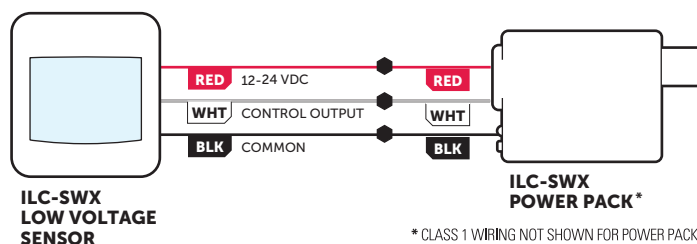

WIRING CONT.

MULTIPLE SENSOR WIRING

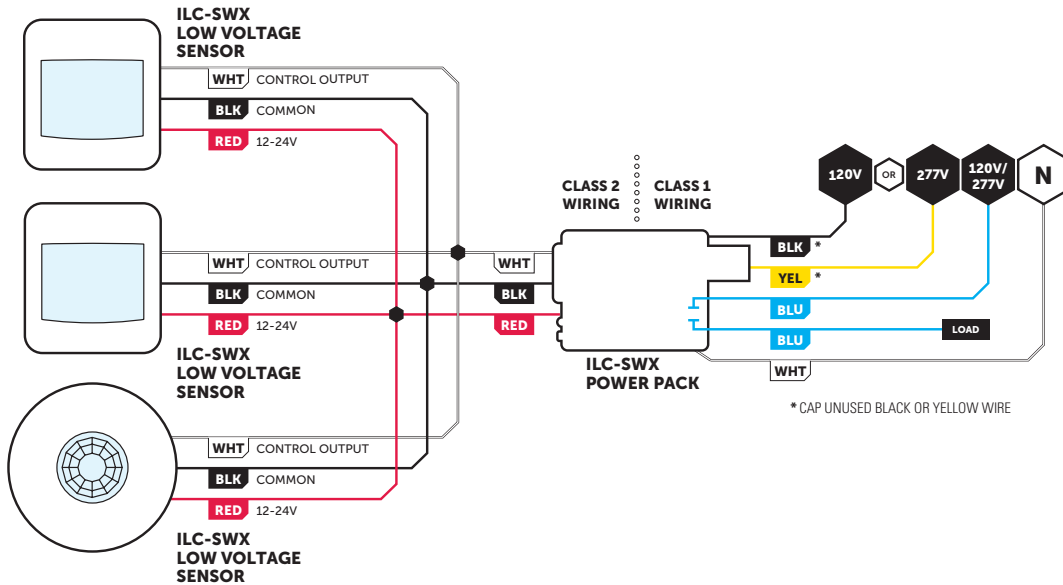

SEPARATE OCCUPANCY ZONE & OCCUPANCY + ON/OFF PHOTOCELL ZONE

- During occupied state, photocell output (blue wire) will turn lights off if ambient light level surpasses threshold and back on if level drops.
- Also configurable to prevent lights from initially turning on, but not to turn them off once lights are on.

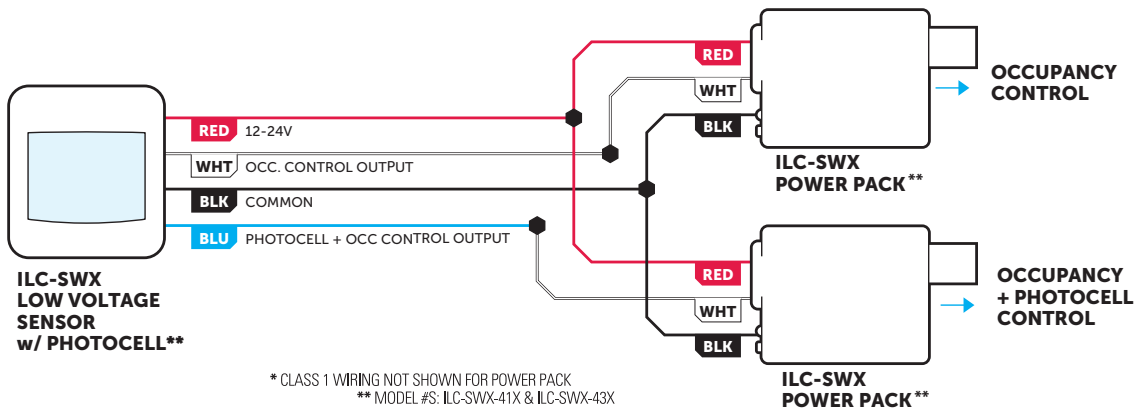

SENSOR AUXILIARY RELAY OUTPUT (-AR OPTION)

- The auxiliary output relay (model option -AR) is designed to interface with many types of building management systems (i.e. BMS), VAV units, and relay panels
- Operation of relay (brown wires) is configurable:
 - By default the relay latches closed when occupancy is detected (white wire goes high)
 - Relay can be configured to alternatively follow the occupancy + photocell (blue wire) output
 - Relay polarity (open vs closed) can also be reversed

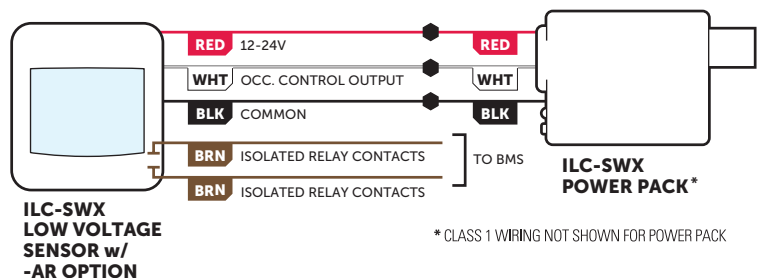

INSTALLATION OPTIONS

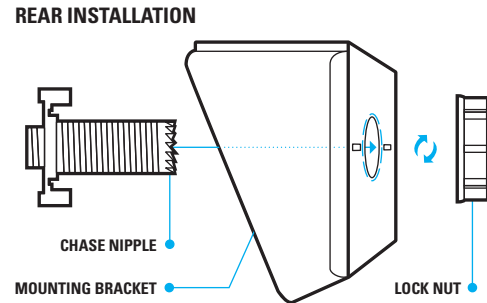
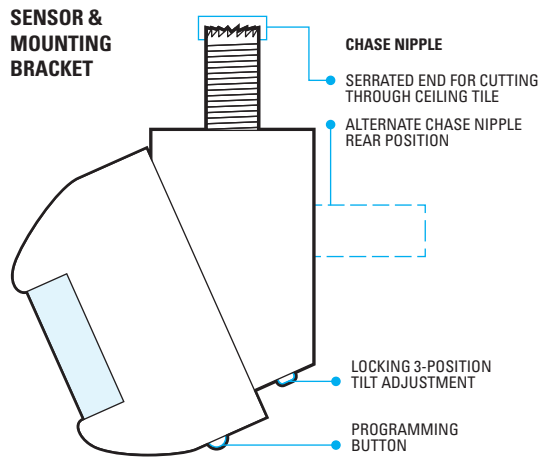

MOUNTING WITH CHASE NIPPLE RECOMMENDED

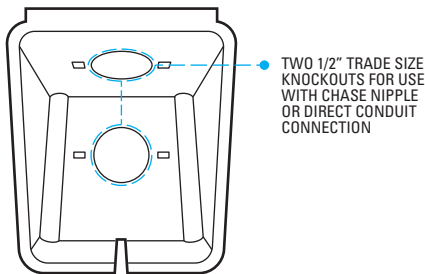

CHASE NIPPLE & LOCK NUT INCLUDED FOR MOUNTING TO CEILING TILE OR 1/2" KNOCKOUT IN JUNCTION BOX

TOP INSTALLATION

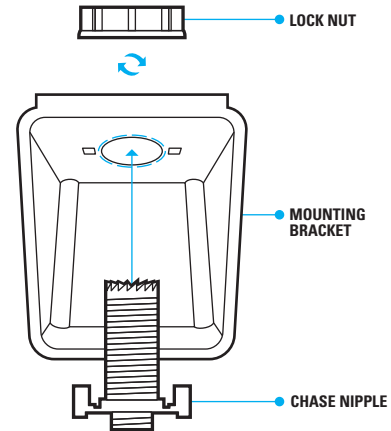

ADDITIONAL MOUNTING METHODS

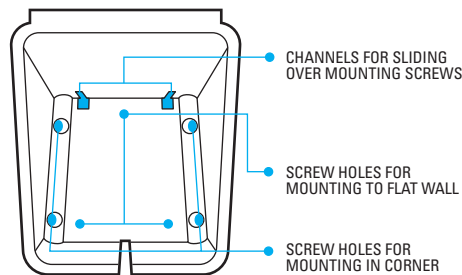

TESTING & TROUBLESHOOTING

TEST MODE

An occupancy test mode with a 5 second time delay is provided in order to efficiently perform walk testing. The sensor will blink White on any detected occupancy (PIR or Acoustic), although its time delay will only be reset by a PIR event. In units equipped with a photocell, the test mode will only factor in occupancy. Ambient daylight conditions are ignored.

TO PUT A SENSOR IN TEST MODE FOR 10 MINUTES:

- Press sensor's pushbutton 2 times, then wait until LED starts blinking back current setting (approx 2 secs).
- Interrupt blinking and press button 1 time to start test mode. After 10 minutes, the sensor's time delay will revert to previous setting.

RESET

To restore factory settings, press and release the pushbutton 8 times, wait 2 seconds, then press and release the pushbutton 3 times again.

CONFIGURATION SETTINGS

FUNCTION #2 - TIME DELAY CONFIGURATION

The length of time after the last occupancy event that the sensor will stay in the occupied state.

CHANGING TIME DELAY SETTINGS:

1. Read through the Time Delay Settings list on the right and note the number of the desired time delay setting (e.g., default is 4 = 10 minutes).
2. Press and release the unit's pushbutton twice, then wait 2 seconds. The white LED will blink back the number of the current setting.
3. At any time after blink back starts, enter number of new setting (from Time Delay Settings table on right).
4. New setting is saved after white LED blinks new number back 3 times. If blue LED double flashes at any time, start process over.

FUNCTION #6 - MICROPHONE (ACOUSTIC DETECTION)

Dual technology sensors prevent non-occupant sounds from resetting the time delay by dynamically reducing the microphones sensitivity at specific frequencies. In some environments, decreasing the sensitivity across all frequencies so that lights go off sooner, may be preferred. A unit's microphone can also be disabled (effectively changing sensor to a PIR only version).

CHANGING MICROPHONE SETTINGS:

1. Press unit's pushbutton 6 times, then wait two seconds. The white LED will blink back the number of current setting (from table on right).
2. At any time after blink back starts, enter number of new setting by pressing the button equal times to choice from table.
3. New setting will be saved after white LED blinks back new number 3 times. If blue LED double flashes at any time, start process over.

FUNCTION #7 - LED INDICATION

By default, the sensor blinks its white LED whenever it detects PIR motion. A unit with dual technology will also blink the LED white when it acoustically detects occupancy. The intensity of this LED can be increased or disabled. Additionally, the LED can be enabled to blink white for only PIR events and blue for an acoustic event.

CHANGING LED INDICATION SETTINGS:

1. Press unit's pushbutton 7 times, then wait two seconds. The white LED will blink back the number of current setting (from table on right).
2. At any time after blink back starts, enter new setting by pressing the button equal times to numbered choices.
3. New setting will be saved after white LED blinks back new number 3 times. If blue LED double flashes at any time, start process over.

FUNCTION #14 - AUXILIARY RELAY OPERATION (-AR OPTION)

By default, the auxiliary relay provided on sensors with the -AR option will follow the state of the sensor's white occupancy output wire (i.e. when the white wire is high indicating occupancy, the auxiliary relay is closed).

CHANGING THE AUXILIARY RELAY OPERATION:

1. Press unit's pushbutton 14 times, then wait two seconds. The LED will blink back white the number of current setting (from table on right).
2. At any time after blink back starts, enter new setting by pressing the button equal times to numbered choices.
3. New setting will be saved after white LED blinks back new number 3 times. If blue LED double flashes at any time, start process over.

FUNCTION #2 - TIME DELAY SETTINGS

SETTING #	DESCRIPTION
1	Test Mode*
2	30 sec
3	5 min
4	10 min (default)
5	15 min
6	20 min
7	30 min

* 5 SEC TIME DELAY, EXPIRES AFTER 10 MIN

EXTENDED TIME DELAYS**

SETTING #	DESCRIPTION
8	1 hr
9	2 hr
10	4 hr
11	8 hr

** EXTENDED TIME DELAYS GREATLY REDUCE ENERGY SAVINGS

FUNCTION #6 - MICROPHONE (ACOUSTIC DETECTION) SETTINGS

SETTING #	DESCRIPTION
2	Normal Operation (default)
3	Reduced Sensitivity
4	Disabled

FUNCTION #7 - LED INDICATION SETTINGS

SETTING #	DESCRIPTION
2	White LED for all occupancy, normal brightness (default)
3	NA
4	Disable LED
5	White LED for PIR, blue for Acoustic, normal brightness
6	NA

FUNCTION #14 - AUXILIARY RELAY OPERATION

SETTING #	DESCRIPTION
2	Disabled
3	Relay closed when occupied (state follows white wire). (default)
4	Relay closed when occupied and insufficient ambient light (state follows Blue wire). Available for ILC-SWX-21x-1-AR and ILC-SWX-23x-1-AR models.
5	Relay open when occupied (state opposite white wire)
6	Relay open when occupied and insufficient ambient light (state opposite blue wire). Available for ILC-SWX-21x-1-AR and ILC-SWX-23x-1-AR models.

PHOTOCELL CONFIGURATION

Along with occupancy based control, units with an integrated photocell can provide on/off or inhibit-only control of lighting based on the amount of ambient light present.

ON/OFF PHOTOCELL CONTROL

- Recommended for public spaces (hallways, entryways, etc) where fully switching of lighting off and on will not cause distraction of occupants.
- Lights are switched off if ambient level surpasses threshold & back on if level drops.

FUNCTION #3 - PHOTOCELL OPERATIONAL MODE

To enable/disable the operation of the photocell, use the following procedure:

CHANGING THE PHOTOCELL OPERATIONAL MODE:

1. Press and release the unit's pushbutton 3 times, then wait 2 seconds. The white LED will blink back the number of the current setting (repeats 3 times before exiting).
2. At any time after blink back starts, enter number of new setting from table on right (e.g., 4 for Occupancy + Initial Inhibit Photocell).
3. New setting is saved after white LED blinks back new number 3 times. If blue LED double flashes at any time, new setting was not saved and process must be repeated.

PHOTOCELL OPERATION NOTES

During periods of occupancy, sensors with an integrated photocell (models ILC-SWX-41x-1, ILC-SWX-43x-1) will signal power packs connected to its blue wire output to turn lighting off when the measured light level is high enough for 5 min. such that turning the lights off will not drop the level below the selected setpoint. During this 5 min. transition time the LED will blink blue at 0.5 second intervals. After lights are turned off, the sensor's LED double blinks blue every 15 seconds as an indication that sufficient ambient light is the reason the lights are being held off. If the ambient light level falls below the setpoint for more than 30 seconds, lights will switch back on. During this transition time the LED also will blink blue at 0.5 second intervals.

FUNCTION #4 - PHOTOCELL SETPOINT

The minimum overall light level that is to be maintained in a space by the sensor is referred to as the "setpoint". This value is user selectable or can be chosen by the Auto-Setpoint function that is built into the sensor.

SETPOINT CONFIGURATION

1. Read through the below setpoint values list and note the number of the desired setpoint (e.g., default is 7 = 25 fc).
2. Press and release the unit's pushbutton 4 times, then wait 2 seconds. The white LED will blink back the number of the current setting in two alternating digits:
Blue LED = 10's digit (1-12 blinks or rapid blink for 0)
White LED = 1's digit (1-9 blinks or rapid blink for 0)
3. At any time after blinking starts, enter number of new setting (see table below).
4. New setting is saved after white LED blinks new setting back 3 times. If blue LED double flashes at any time, an error condition exists and process must be repeated.

FUNCTION #4 - SETPOINT VALUE TABLE

SETTING #	DESCRIPTION
2	Run Auto-Setpoint*
3	2.5 fc
4	5.0 fc
5	10.0 fc
6	15.0 fc
7	25 fc (default)
8	35 fc
9	50 fc
10	75 fc
11	100 fc

Manual Setpoint Options

INITIAL INHIBIT ONLY PHOTOCELL CONTROL

- Lighting is held off if sufficient ambient light level is present upon initial occupancy.
- Lighting will turn on if light level drops below setpoint.
- Lighting will only turn off from vacancy or a manual switch, never from daylight.

FUNCTION #3 - PHOTOCELL OPERATIONAL MODES

SETTING #	DESCRIPTION	MODEL # NOTES
2	Occupancy + On/Off Photocell Control (Photocell Enabled)	Default for ILC-SWX-41x-1 & ILC-SWX-43x-1
3	Unused	
4	Occupancy + Initial Inhibit Photocell Control (Photocell Enabled)	
5	Occupancy only (Photocell Disabled)	Default for ILC-SWX-40x-1 & ILC-SWX-42x-1

*AUTO-SETPOINT SELECTION DETAILS

- Once setting 2 "Run Auto-Setpoint" has been selected (by following steps 1-4 on left), the sensor's LED will alternate blue and white for 30 seconds. During this time user should move away from sensor.
- Lights connected to the blue wire will then be cycled in order for sensor to calculate the controlled (artificial) light level. This is done by subtracting the light level with the lights off (relay open) from the light level with the lights on (relay closed).
- A setpoint will then be chosen using the following conditions:
 - If controlled level is less than 3 fc, the application is considered open loop and the setpoint will be set to 25 fc.
 - If controlled level is between 3 and 100 fc, setpoint will be set to that level times 1.25.
 - If controlled level is greater than 100 fc the setpoint will be set to 125 fc.
- Unit will immediately start operating with new setpoint (i.e. blue LED may begin flashing indicating it will transition lights soon)
- To check auto selected setpoint, press and release button 4 times. Setpoint will be blinked back in two alternating digits:
Blue LED = 10's digit (1-9 blinks or rapid blink for 0)
White LED = 1's digit (1-9 blinks or rapid blink for 0)