

LightSync Ceiling Sensor Installation Details

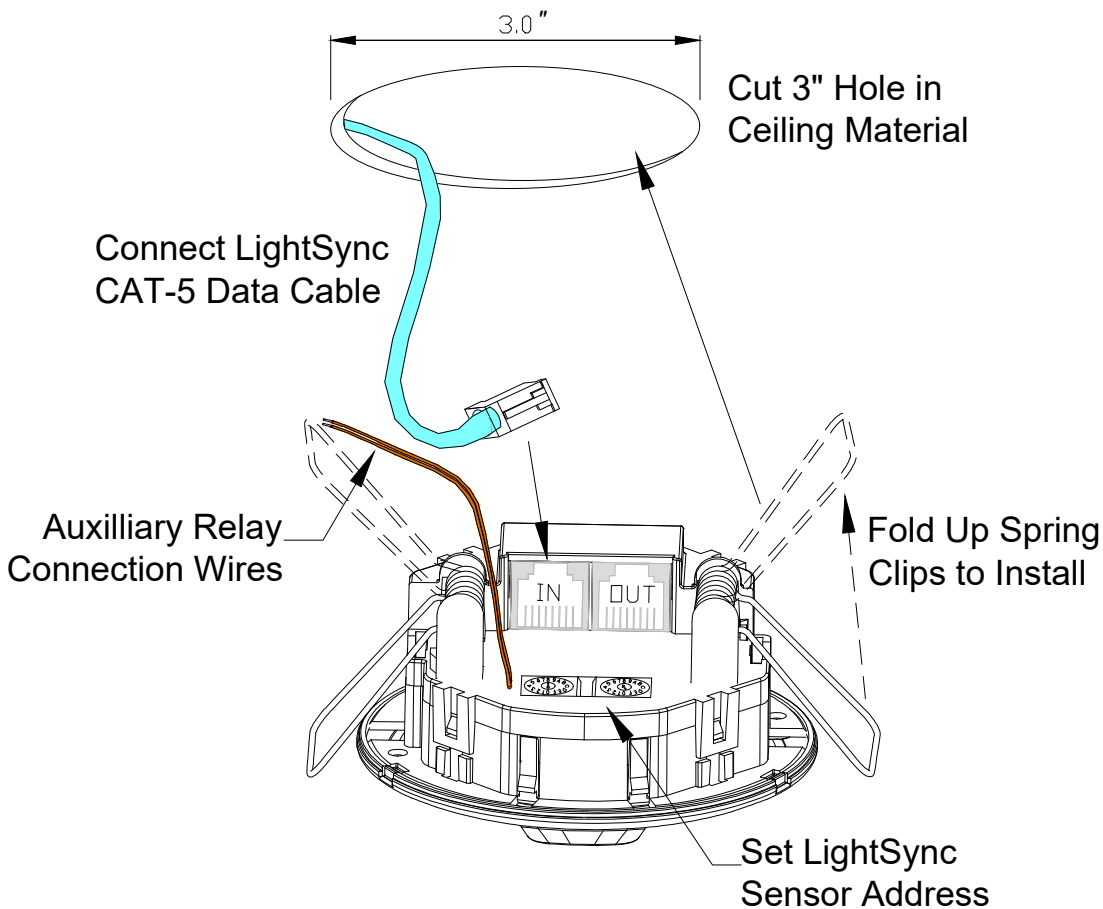

Installing the LightSync Ceiling Sensor:

- Install in standard construction ceiling by cutting a 3" (76mm) hole
- Set LightSync ceiling sensor address per the riser
- Connect CAT-5 data cable from last LS device or controller
- Connect auxiliary relay wires to external system if required
- Fold back spring retaining clips and insert sensor into mounting hole, with a maximum ceiling thickness of 1 inch.

Note: For mounting to mud ring or junction box see page 2

Mounting Height:

Standard 8' -15'

- Small Motion lens - 600 sq. ft.
- Large Motion lens - 2,000 sq. ft.

Junction Box Installation Details

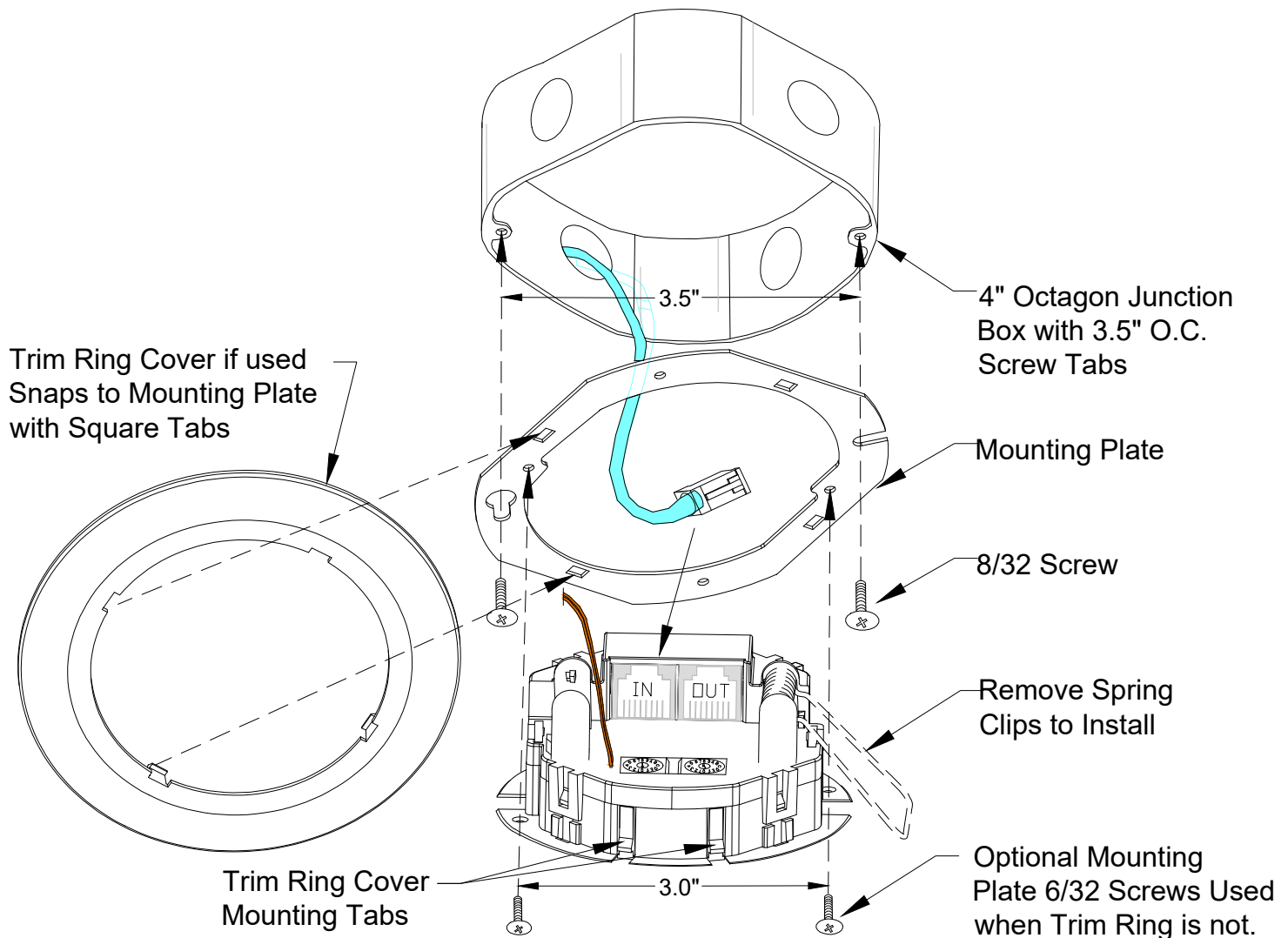

Installing the LightSync Ceiling Sensor to a Junction Box:

- Remove spring clips from sensor
- Install mounting plate to a standard 4" x 2-1/8" deep octagonal junction box with 3.5" O.C. screw tabs or fixture ears (Raco 165, Carvin 54171).
- For a square junction box with a 4" Octagon mud ring, attach the mounting plate to the screw tabs or fixture ears (mud ring Carvin 4" 52C4 or 4-11/16" 72C4)
- Trim ring cover can be attached directly to mounting bracket with the square tabs, the sensor is then attached to the trim ring using four mounting tabs on the sides of sensor body