

LightLEEDer

Remote 20 Amp Dimming Relay with Emergency Bypass

Overview

The ILC Remote 20 Amp, Emergency Bypass Relay combines normal relay operation with a UL 924 bypass relay in one convenient package. Relays are available in both a wired (R20D-EM) and wireless (WR20D-EM) version that uses the 915MHz radio frequency for communication to ILC wireless devices. When normal power is lost the EM relay will automatically force ON the EM load and send dimming to 100%. When normal power is restored the device will return to normal control. The R20D-EM and WR20D-EM have a relay test button, and a wired input that can be used for a remote test switch or as an override connection from a fire alarm system.

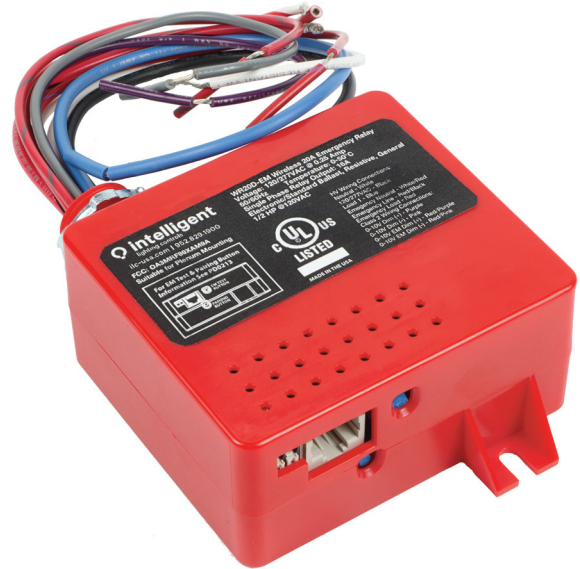

Features

- **Made in the USA**
- **Emergency and Normal** power control combined in one device
- **UL 924** rated
- **EM Relay** rated up to 20 Amp @120/277VAC
- **Normal Relay** rated up to 20 Amp @120/277VAC
- **EM Load follow** operation of normal load control
- **Test button** for local Test operation
- **Override Input** for remote Emergency test switch or fire alarm system override
- **Plenum rated**
- **Direct mounting** at power junction box or light fixture with 1/2" K.O.
- **Digital CAT-5** ready control from LLEVO controller up to 100 feet
- **Wireless Control** up to 100 feet line-of-sight from LLEVO-W wireless controller or wireless-direct-linked to LightSync digital wireless devices

Warranty

Five-year limited warranty

Ordering

Remote 20 Amp Dimming Relay with Emergency Bypass

Series:

R20D-EM = Remote 20 Amp Dimming Relay with EM load

WR20D-EM = Wireless Remote 20 Amp Dimming Relay with EM load

LightLEEDer

Remote 20 Amp Dimming relay with Emergency Bypass

Physical

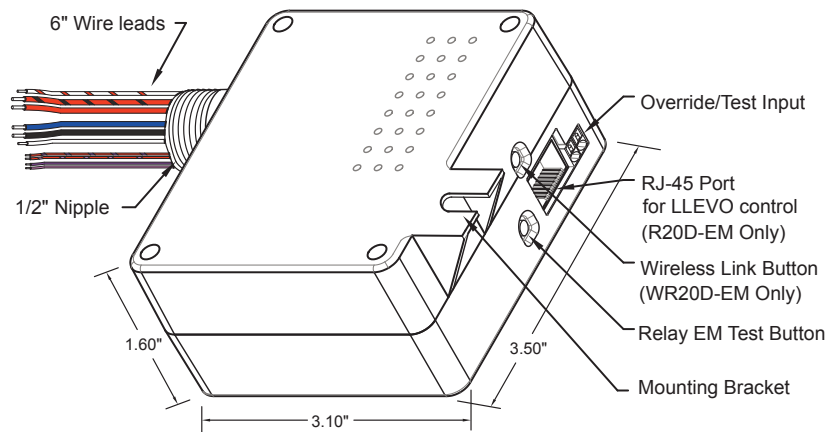

R20D-EM / WR20D-EM

Specifications

Safeguards:

- LED electronic load inrush rated
- 600VAC rated wire leads including 0-10V leads
- 4000V Isolation 0-10VDC dimming

Physical:

- Dimensions 3.50" x 3.10" x 1.60"
- Polycarbonate plastic enclosure
- 6" wire leads for connections provided
- Color coded leads for easy wiring
- 1/2" nipple for mounting to electrical box
- Conduit nut provided

Electrical:

- 20 Amps, 120/277VAC tungsten
- 16 Amps, 120/277VAC electronic ballast, LED, CFL
- 1/4HP @ 120VAC motor load
- Plug-load compatible
- 100mA Sink 0-10V dimming loads combined
- SCCR: 5kA

Wireless Control:

- 915MHz radio transceiver
- 100 foot line-of-sight communication
- Wireless-direct-link to Wireless G3 switches and sensors
- Link to LLEVO-W wireless controller for network control
- Secure wireless encrypted communication between devices

Wired Control:

- RJ-45 connector for control from any LLEVO panel

Override Test Input:

- 10-28VAC/DC 5mA input current
- Test button on relay

Operating Environment:

- Location: Interior space
- Operating Temperature: 0° to 50° C
- Humidity: 10% - 90% Non-condensing
- Atmosphere: Non-explosive/corrosive
- Vibration: Stationary

Certifications:

- UL CUL 916/924
- Plenum Rated UL 2043