

LightSync Digital

Touch Button Switch

Overview

The LightSync Digital Touch Switch Station offers a durable switch that is resistant to impact and vandalism. Switch stations are available with 1 to 3 highly durable push button switches and have a status LED associated with each button. Each button may be programmed to control any relay(s), group(s) or preset(s) throughout the network. Switch Stations are available in four colors or stainless steel.



Plate not included

Features

- **Made in the USA**
- **Digital CAT-5 Ready**
- **Durable** vandal resistant data line switch station
- **Buttons** range from 1 to 3 per station
- **Programmable buttons** control any relay(s), group(s) or preset(s)
- **Status LEDs** for indicating the true state of a relay, group or preset
- **Switch Stations** are available in white, ivory, gray, black, stainless steel
- **Mounts** in a standard single gang box
- **Remote mount** anywhere on the LightSync network
- **Self powered** from the network
- **Addressable** rotary switches

Warranty

Five-year limited warranty

Ordering

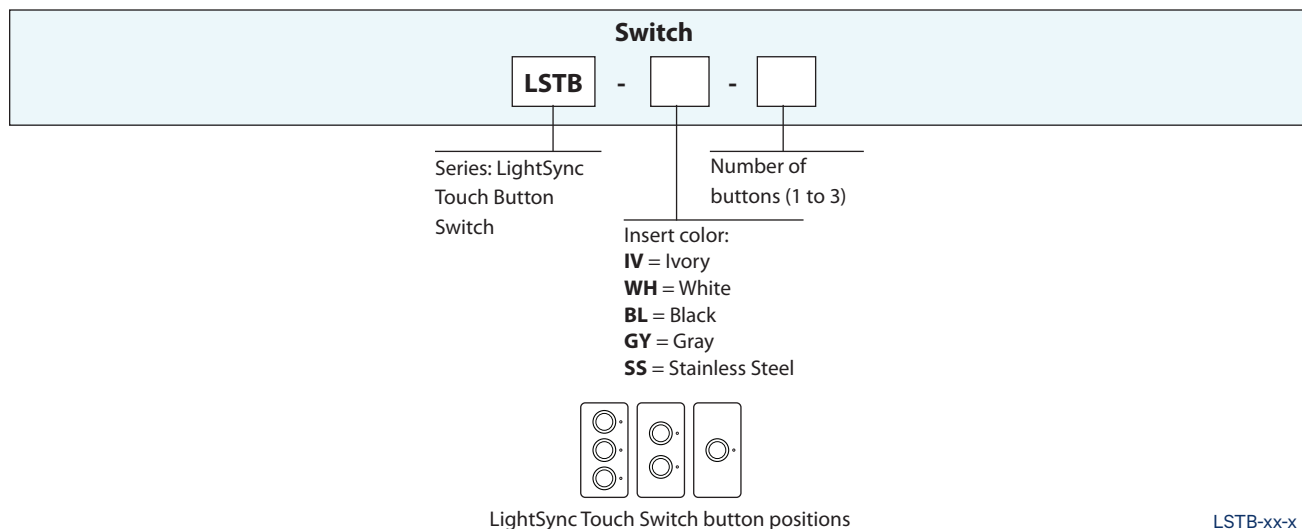

LSTB-xx-x Rev.B

LightSync Digital

Touch Button Switch

Physical

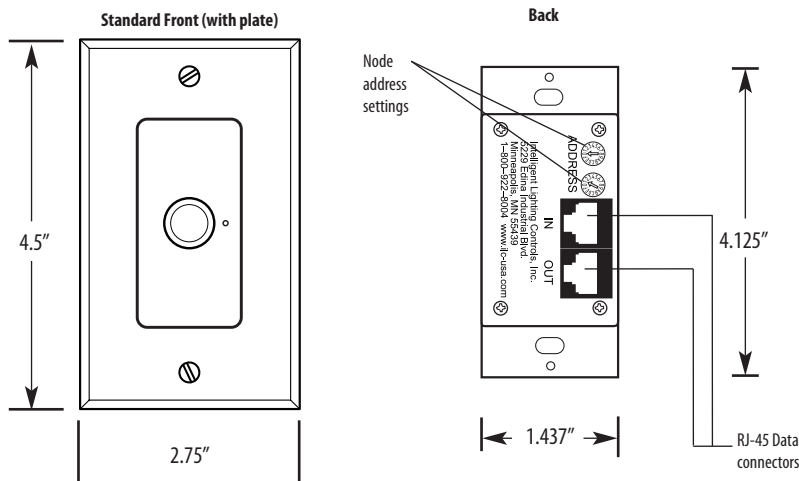

Specifications

Physical:

- Standard single gang mounting
- Digital addressing switches
- RJ45 connectors provided for easy connection
- Mounting screws provided
- Stainless Steel Switch

Electrical:

- Powered from the panel or LightSync network
- 200,000 electrical life cycles

Operating Environment:

- Location: Interior space
- Operating Temp.: 0° to 50° C
- Humidity: 10% - 90% Non-condensing
- Atmosphere: Non-explosive/corrosive
- Vibration: Stationary
- Switch Ingress Protection: IP68

Certifications and Approvals:

- FCC Part 15