

LightLEEDer 2 Load Room Controller

Remote Panel Details

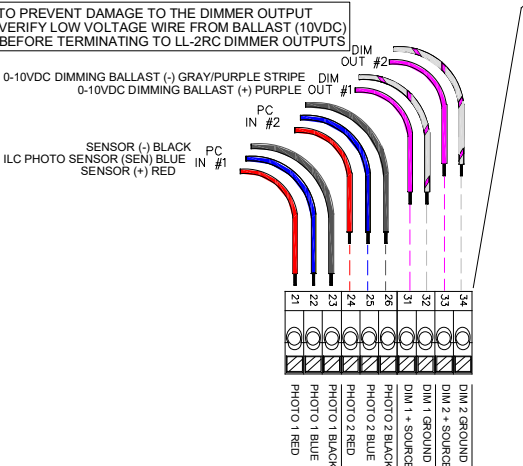
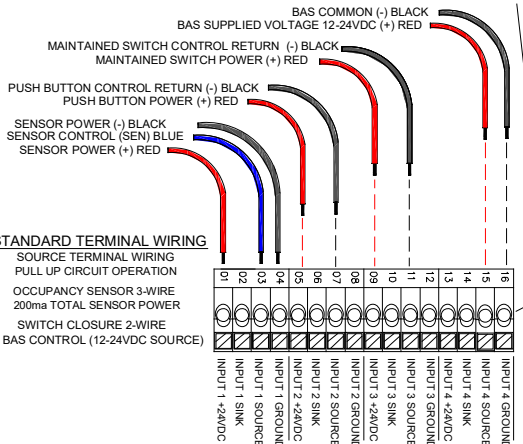
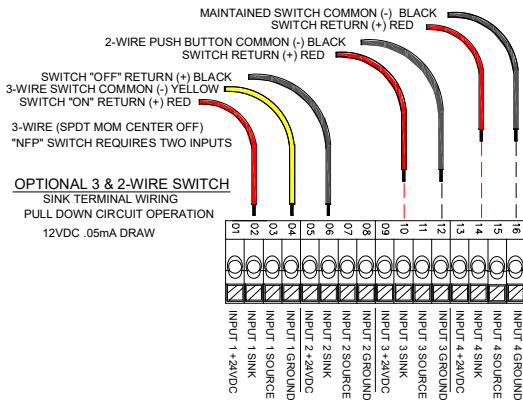

NETWORKING RJ-45 CONNECTORS
USED WHEN LL-2RC PANELS ARE USED IN A
LightLEEDer PANEL NETWORK

LOCAL BUS RJ-45 CONNECTOR FOR
CONNECTING UP TO 2 LightSync SWITCHES

OPTIONAL - MOUNTING
SCREW HOLES

LOW VOLTAGE WIRING SECTION
TWO 1/2' KO FOR CLASS 2 WIRING

ATTENTION INSTALLING CONTRACTOR
YOU ARE RERQUIRED TO SET THE ADDRESS
OF THIS DEVICE ACCORDING TO THE RISER
PROVIDED BY ILC. FAILURE TO DO SO WILL
MAKE THE UNIT NON-FUNCTIONAL

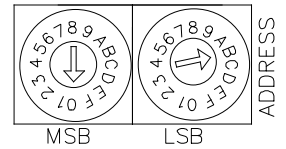

PANEL ADDRESS WHEELS (2-DIGIT HEX CODE)
FF = STAND ALONE UNIT
01 to 10 = 16 NETWORK EXPANSION NODES
(EXAMPLE: "0B" IS THE 11th HEX CODE)

FOUR INPUT TERMINALS FOR OCCUPANCY
SENSORS OR 2-WIRE SWITCHES
(3-WIRE SWITCHES USES TWO INPUTS)

TWO DIGITAL LightSync PHOTOCELL INPUTS
& TWO 0-10VDC DIMMING OUTPUTS

FACTORY SETTING (DIMMER SINK)
"A" = GND * STANDARD
"B" = 5V

0-10VDC DIMMER OUTPUT SELECTION
C = SINK VOLTAGE (0-10VDC BALLAST)

CONSULT FACTORY FOR USE OF
"A" DIRECT DRIVE (ANALOG OUTPUT)
"B" SOURCE VOLTAGE SETTING
OPTIONS & LIMITATIONS

RELAY #1 RIBBON CONNECTOR
RELAY #2 RIBBON CONNECTOR

VOLTAGE DIVIDER & TWO R40-1 RELAYS
UL LISTED FOR 30AMPS
TUNGSTEN / BALLAST
120/277/347VAC, 1.5HP MOTOR
SCCR 18,000A @ 347VAC

FIRMWARE PROGRAMMING PORT

STATUS LED INDICATORS
PWR = POWER TO CONTROLLER
OK = PROCESSOR RUNNING
COM = DATA LINE COMMUNICATION ACTIVE

20/10VAC POWER FROM TRANSFORMER
RED/RED = 20V RED/YELLOW = 10V

3/4" THREADED NIPPLE FOR CONNECTION
TO FIELD J-BOX OR RACEWAY

LINE / LOAD WIRE CONNECTIONS



CONTROL TRANSFORMER WIRE CONNECTIONS

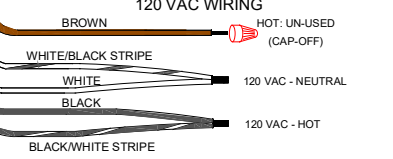

347 VAC WIRING CANADIAN VERSION

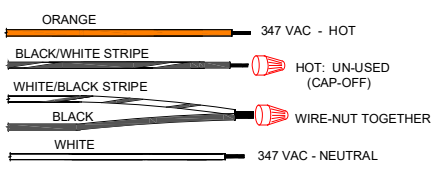

277 VAC WIRING

