

LVS EPC-1 Emergency By-Pass Wiring Details

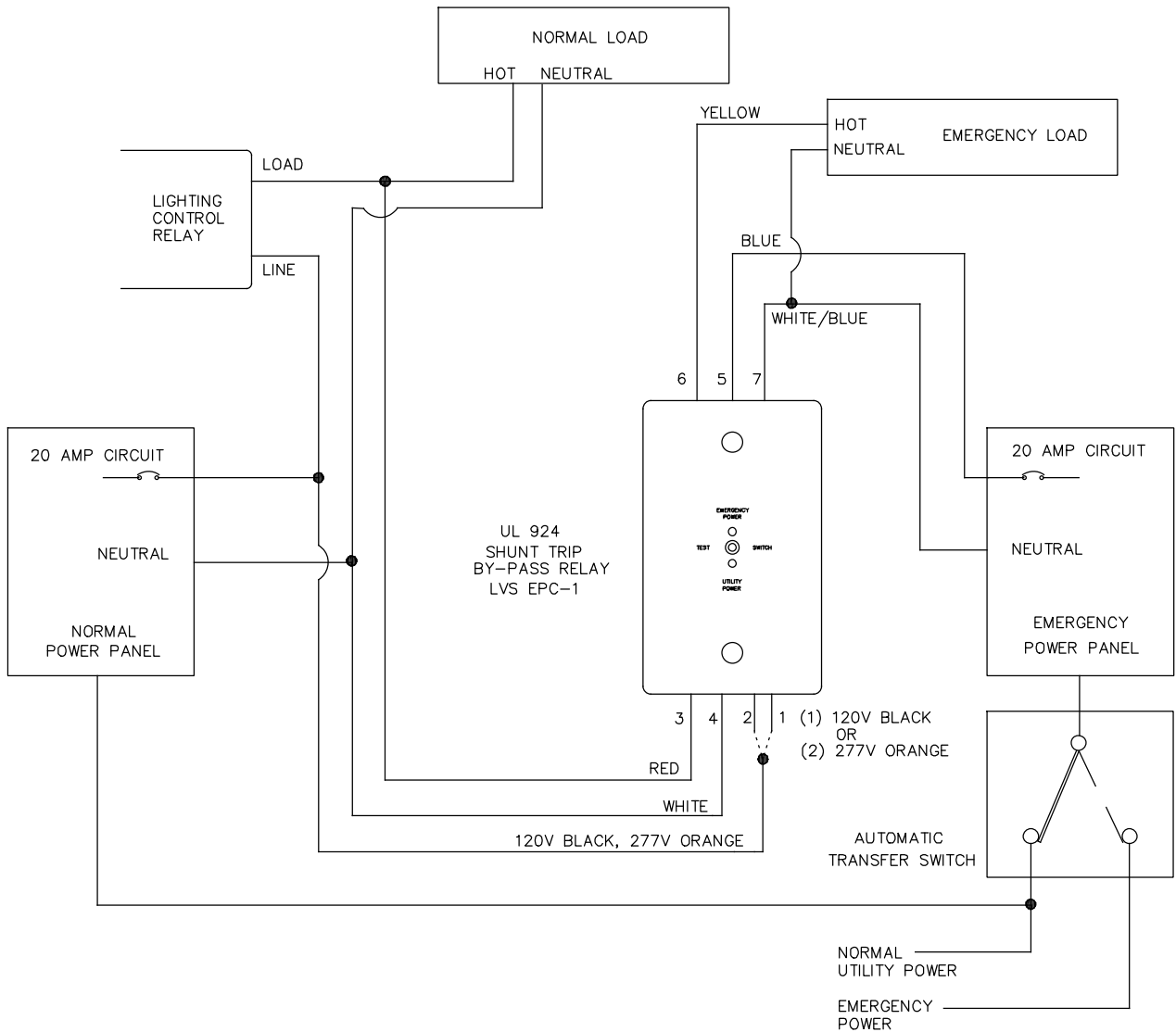

This is a typical wiring diagram for a lighting control panel that is controlling normal loads and emergency loads simultaneously. This is accomplished by signaling the Emergency Power Control unit (EPC-1) from the lighting controller. With the use of an EPC-1 during normal conditions, the relay panel controls the normal loads and signals the EPC-1 to control the emergency loads. During a power outage, the EPC-1 by-passes the normal load and illuminates the emergency lighting loads only.

Wire the EPC-1 as shown above for normal and emergency power. Connect the black wire (1) if using 120VAC or the orange wire (2) if using 277VAC, cap the unused wire.