

# LightLEEDer Serial Communications Module Wiring Details

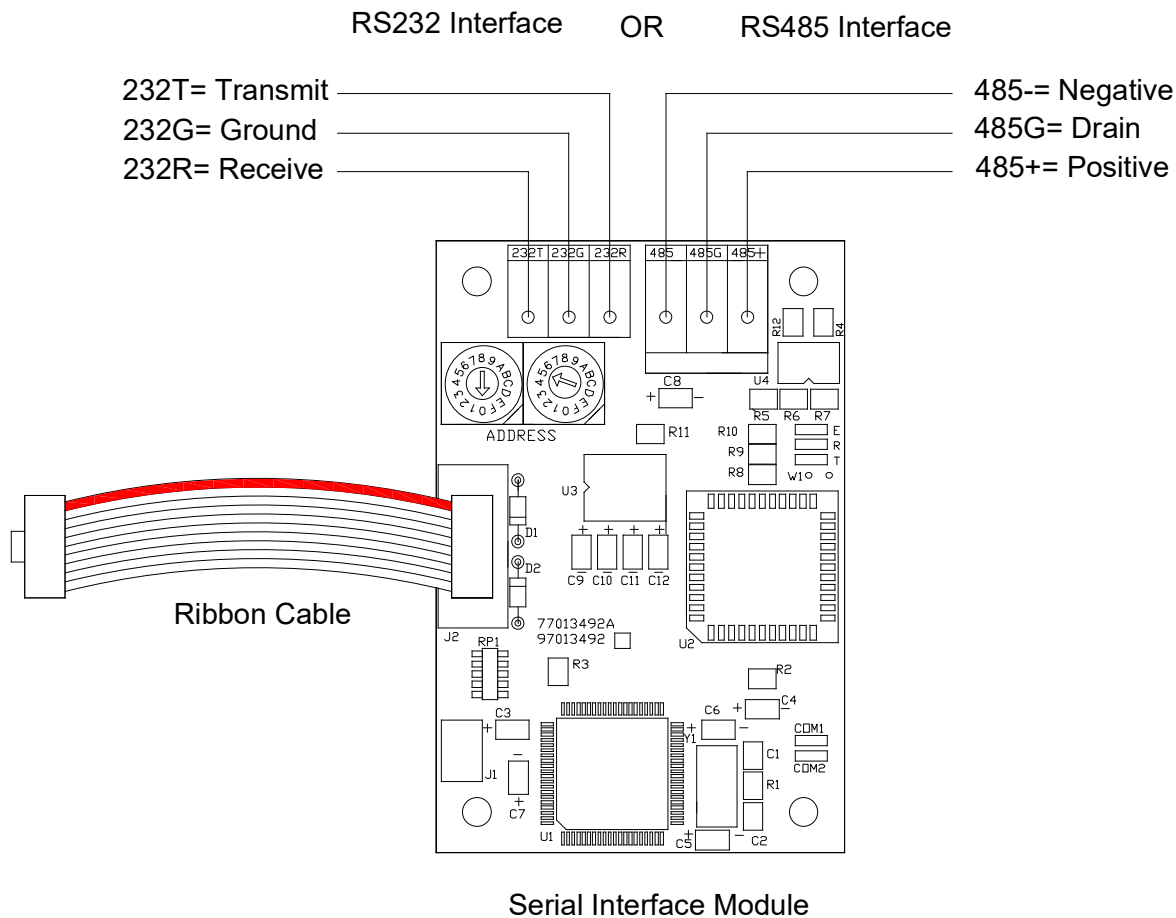

## General Information:

The ribbon cable interfaces the serial module to the LightLEEDer controller. It attaches to one of the 4 add-on ports available, and needs to be enabled through the keypad or software. If you have a module with the Alternate Serial Interface firmware (for the ILC ASCII open protocol), the module will need to be connected to port 4.

Terminate to either the RS232 or RS485 removable terminal blocks as shown in the configuration above. Use the appropriate wire for the communications type, keeping the cable length within the specifications of the communications used.

**RS232:** If needed, a DB9 connector with leads can be terminated to the RS232 connection.

**RS485:** Terminate the RS485 drain/ground wire only on one end to prevent ground loops and data offsets. A 100 ohm terminating resistor can be installed at the connector if this device is at the end of the data line.